

# NITTAN



# EVC-DP

## PHOTOELECTRIC SMOKE DETECTOR

instruction manual



• Ref No: NISM/EVC-DP/05 • Date: 03.02.20 • Issue: 5

• evolution • EVC-DP • photoelectric smoke detector instruction manual



Quality System Certificate No. 041  
Assessed to BS EN ISO 9001

# NITTAN

**NITTAN EUROPE LTD.** Hipley Street, Old Woking, Surrey, England, GU22 9LQ. UK  
Tel: +44 (0) 1483 769555 • Fax: +44 (0) 1483 756686  
Web Site: [www.nittan.co.uk](http://www.nittan.co.uk) • E-mail: [sales@nittan.co.uk](mailto:sales@nittan.co.uk)



## evolution.....

The **EVC-DP** Photoelectric Smoke Detector forms part of a range of fire detectors from Nittan Europe Ltd. called evolution.

The **EVC-DP** is an elegantly designed, low profile detector which is aesthetically pleasing, thus enabling it to blend unobtrusively into modern working environments.

The **EVC-DP** is compatible with other existing conventional fire detection systems.

# evolution



## CONTENTS:-

### Section 1

Introduction Page 3

### Section 2

Operation Page 3

### Section 3

Detector Models Page 4

### Section 4

Base Models Page 4

### Section 5

Installation Page 4

### Section 6

Maintenance & Cleaning Page 5

### Section 7

Specification Page 7

### Section 8

Environmental Parameters: Page 8  
 - Temperature Page 8  
 - Humidity Page 8

### Section 9

EMC Page 8

### Section 10

Connections Page 9

### Section 11

Dimensions Page 9

### Section 12

Disposal Page 10

### Section 13

ROHS Compliance Statement Page 10

## Section 1 - INTRODUCTION

The **EVC-DP** is an attractively-styled, low profile photoelectric smoke detector for use in conventional fire detection systems.

The **EVC-DP** has a chemically etched, stainless steel insect screen therefore reducing the ingress of insects and airborne contaminants.

### **EVC-DP** features:

- Optical detector, detecting visible particles of combustion
- Low profile, stylish appearance
- Supplied with protective dust cover, (remove during commissioning)
- Non-polarised terminals
- Unauthorised head removal signal facility
- Low monitoring current
- OMNIVIEW™ 360° LED fire alarm indicator
- Remote indicator output
- Compatible with UB-4, UB-4SD, STB-4SE.

## Section 2 - OPERATION

The smoke chamber of the **EVC-DP** is constructed so that light cannot enter from outside, but smoke can pass through the chamber slots. The **EVC-DP** utilises the light scatter sensing principle. The LED's pulse every 4 seconds to maintain a low monitoring current. A quick charge time (1 minute in clean air) is also achieved. The detector incorporates an alarm verification function which requires two successive pulses before an alarm is given.

The interval between the first and second pulse is automatically reduced to 1 second after the first alarm level (3%/m) is monitored. The final Alarm threshold is set at 7.6%/m. The detector design provides strong immunity to air velocities, contamination and RF interference.

The geometry of the smoke chamber and optics support assembly is designed to give the best possible signal to noise ratio, resulting in excellent response characteristics.



## Section 3 - DETECTOR MODELS

The **EVC-DP** photoelectric smoke detector is supplied, as standard, with four terminals.

The **EVC-DP** has the facility to activate a remote LED indicator or auxiliary function, as standard.

The terminals on the EVC-DP detector head are configured as follows:-

Terminal 1 = zone negative in

Terminal 3 = zone positive in/out

Terminal 6 = zone negative out

Terminal 5 = 2 mA @ 24V d.c. switched output

## Section 4 - BASE MODELS

A variety of bases are available for use with the **EVC-DP** detector.

It is important to use the correct base for each application.

The standard range available is as follows:-

- i) UB-4 base: having 4 terminals, for standard use with **EVC-DP** detector including the auxiliary output function.
- ii) UB-4SD base: This is identical to the standard UB-4 base, but also includes a schottky diode for head removal fault monitoring. The schottky diode is used in some fire systems to ensure power is maintained, in the event of an unauthorised detector head removal, to other detectors further on the zone.
- iii) STB-4SE base: Similar to UB-4 base, except deeper.

## Section 5 - INSTALLATION

In normal use, the **EVC-DP** detector will be installed at ceiling level. Pass the field wiring through the cable hole in the centre and from the rear of the base. Offer up and affix the base to the ceiling or conduit fitting with screws via the base mounting holes. Connect the field wiring to the base terminals, as detailed on page 9 making sure the wiring does not obstruct fitting of the detector head. Fit the detector head by inserting it into the base and turning clockwise until the notch in the detector rim aligns with base locking screw. The OMNIVIEW™ 360° indicator permits visibility from any angle.



Fit the plastic dust cover supplied over the detector to keep out dust etc, until the system is commissioned. If the dust cover is not fitted and the environment is slightly dusty, such as when building work is being completed, for example, problems of false alarms are likely to occur after commissioning unless cleaning of the detector is undertaken. At commissioning, the dust cover should be removed and discarded.

**NOTE: THE PLASTIC DUST COVER MUST BE REMOVED FROM THE DETECTOR IN ORDER FOR THE DETECTOR TO FUNCTION CORRECTLY.**

## Section 6 - MAINTENANCE AND CLEANING

### Maintenance:

The **EVC-DP** detector is a high quality product engineered for reliability. In order to obtain optimum performance, periodic maintenance is required. If proper preventative maintenance is not carried out, there is a likelihood of malfunction, as a dirty detector is more likely to cause a false alarm.

### Servicing:

Servicing of the system should be carried out in accordance with the requirements of BS 5839 Part 1, Fire Detection and Alarm Systems for Buildings: Code of Practice for System Design, Installation and Servicing.

The maintenance procedures described below should be conducted with the following frequency:

One month after installation:	Routine Inspection and every 3 months thereafter.
Every 6 months:	Operational Test
Every 12 months:	Functional Test and Cleaning.

All above frequencies of maintenance are dependent on ambient conditions.

**Routine Inspection:**

- i) Ensure the detector head is secure and undamaged.
- ii) Check the smoke entry apertures are in no way obstructed.
- iii) Ensure the surface of the detector's outer cover is clean. If there are deposits due to the presence of oil vapour, dust etc, then the detector should be cleaned in accordance with the cleaning instructions detailed later in this manual. It may be advisable to ensure that such cleaning is conducted regularly in the future.
- iv) Ensure no equipment which may generate combustion products or fine airborne particles, has been installed in the vicinity of the detector since the last routine inspection. If such equipment has been installed, then you should notify the Fire Safety Officer or other competent authority that its presence may cause false alarms.

**Operational Test:**

The purpose of the Operational Test is to confirm the detector's correct operation in response to a smoke condition.

- i) Take any necessary precautions at the control panel to limit the sounding of the alarm sounders/bells and any fire service summoning device.
- ii) Introduce a discrete amount of smoke into the detector head, e.g. using a 'No Climb - Testifire' smoke test head. Check that the detector gives an alarm condition within 15 seconds. Check the LED indicator on the **EVC-DP** detector illuminates and any remote indicator LED fitted also illuminates.
- iii) After the detector has given the alarm condition, reset the detector from the control panel. It may be necessary to allow a short time to elapse before resetting the detector, to allow any residual smoke from the test to disperse.
- iv) Before proceeding to the next detector, ensure that the detector just tested does not re-operate due to the presence of residual smoke.

evolution



**Functional Test:**

The detector may be returned to Nittan Europe Ltd. for functional testing.

**Cleaning:**

Note: The detector head should NOT be disassembled.

- i) Carefully remove the detector head from its base.
- ii) Use a soft, lint-free cloth, moistened with alcohol for sticky deposits, to clean the plastic casing.
- iii) Using a soft bristle brush (e.g. an artist’s paint- brush) carefully brush between the vanes in a linear motion away from the smoke entry apertures.
- iv) It is permissible to blow dust from the chamber, without removing the cover, using a clean air line.
- v) If the unit needs further cleaning, or is damaged or corroded, please return the complete detector to Nittan Europe Ltd. for service.

## Section 7 - SPECIFICATIONS

Model Reference:	-	EVC-DP
Computer Reference:	-	F02-82215
Detector Type:	-	Photoelectric smoke detector
Sensitivity	-	6.5% Obscuration per metre
Supply Voltage:	-	24V dc nominal (range 16V to 32V)
Voltage Ripple:	-	20% maximum
Alarm Characteristics:	-	6V d.c. in series with 375R between +(terminal 3) and - (terminals 1,6) at 25°C

evolution



Monitoring Current:	-	40µA max. at 24V d.c.
Alarm Current:	-	50mA. max.
Charging Time:	-	1 minute in clean air
Ambient Temperature Range:	-	-10°C to +55°C
Standard:	-	EN54-7:2018
CPR Certificate:	-	2831-CPR-F1874
Declaration of Performance:	-	F1874
EMC Conformance:	-	BS EN50130-4:2011 (Immunity) BS EN61000-6-3:2007+ A1:2011 (Emissions)
Mass:	-	118g (excluding base)
IP Rating:	-	41

## Section 8 - ENVIRONMENTAL PARAMETERS

### Temperature Considerations:

Over the range from -10°C to +55°C.

### Humidity:

Relative Humidity of up to 95%, measured at 50°C, non condensing.

## Section 9 - EMC

### Installation

The installation shall be in accordance with the regulations either of the approval body for an approved system, or otherwise, to the national code of practice/ regulations for the installation of the fire alarm system, e.g. BS 5839 part 1.

### Electromagnetic Compatibility (EMC)

In a site where there is an unusually high level of potential electrical interference, e.g. where heavy currents are being switched or where high levels of R.F. are prevalent, care then must be taken in the type and routing of cables. Particular care should be given to the separation of zone wiring from the cable carrying the interference.



## Section 10 - CONNECTIONS

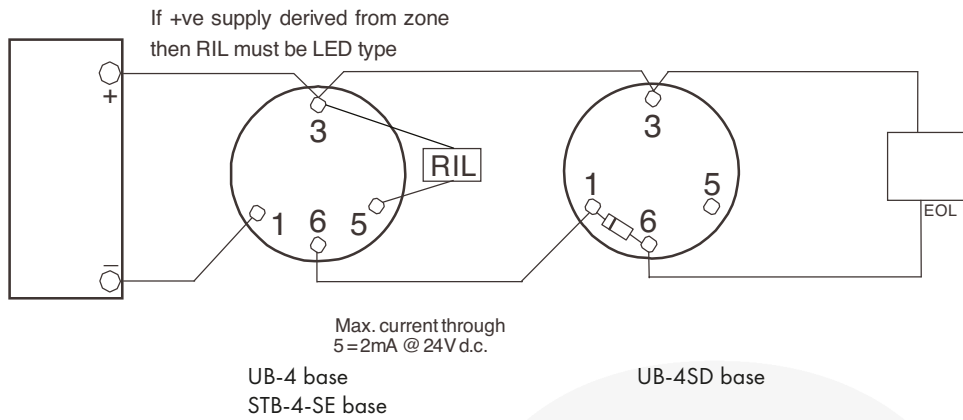

RIL must be 6V, 2mA max.

## Section 11 - DIMENSIONS

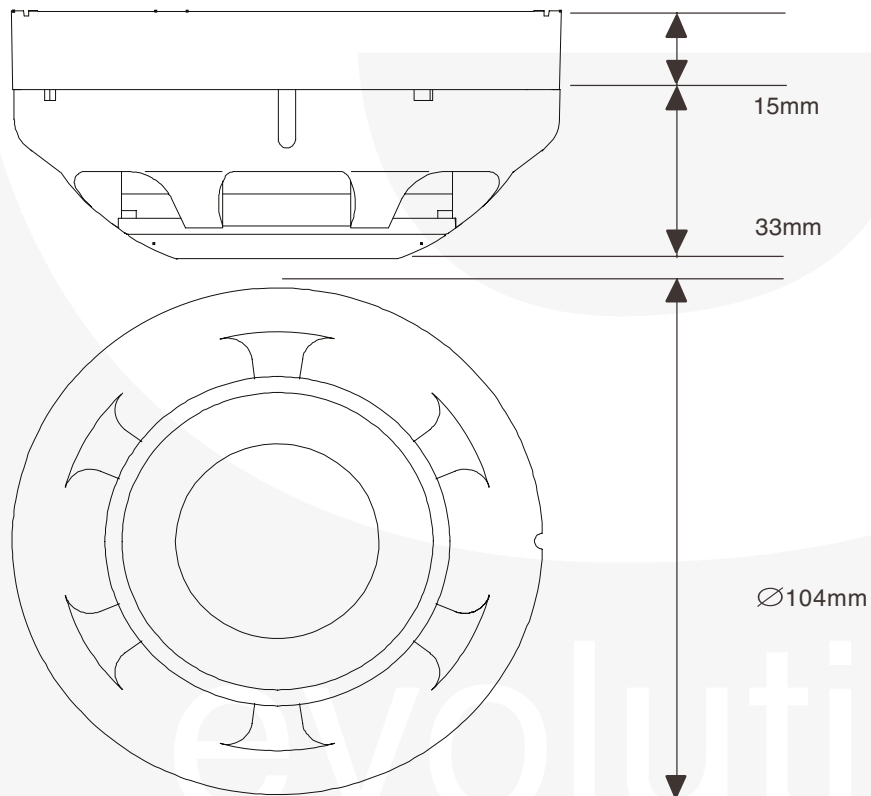



# RoHS

## Section 12 - DISPOSAL

This symbol on the **EVC-DP** indicates that this product must not be disposed of with household waste. Instead, it is your responsibility to dispose of your waste equipment by handing it over to a designated collection point for the recycling of waste electrical and electronic equipment. The separate collection and recycling of your waste equipment at the time of disposal will help to conserve natural resources and ensure that it is recycled in a manner that protects human health and the environment. For more information about where you can drop off your waste equipment for recycling, please contact your local city office or your household waste disposal service.

## Section 13 - ROHS COMPLIANCE STATEMENT

(RoHS compliant and lead-free)

This product complies with the European Union RoHS (Restriction of Hazardous Substances) directive (EU) 2015/ 863 which restricts the use of the following ten hazardous materials in the manufacture of electronic and electrical equipment.

- Cadmium (Cd): < 100 ppm
- Lead (Pb): < 1000 ppm
- Mercury (Hg): < 1000 ppm
- Hexavalent Chromium (Cr VI): < 1000 ppm
- Polybrominated Biphenyls (PBB): < 1000 ppm
- Polybrominated Diphenyl Ethers (PBDE): < 1000 ppm
- Bis(2-Ethylhexyl) phthalate (DEHP): < 1000 ppm
- Benzyl butyl phthalate (BBP): < 1000 ppm
- Dibutyl phthalate (DBP): < 1000 ppm
- Diisobutyl phthalate (DIBP): < 1000 ppm

# evolution