

HEAT AND CARBON MONOXIDE ALARM

PRODUCT FEATURES:

- Hush Nuisance Alarms
- Loose Neutral Monitoring
- Loud 85dB Alarm
- Tamper Proof Design
- Low Battery Warning
- 10-year Life Lithium Battery
- RF Module Compatible (HSSA/MOD/RF-PRO)
- The Ultimate Retrofit Solution



DESCRIPTION:

The HSSA/HCO/10 & The HSSA/HCO/10H are 230v powered Heat and Carbon Monoxide Alarms with 10-year Rechargeable Lithium Batteries for Backup. The alarm contains a highly accurate sensor, thoroughly tested throughout the manufacturing process for fewer false activations and has been extensively calibrated for optimal fire safety.

TECHNICAL SPECIFICATION:

Grade of Alarm:	D1
Detection Type:	Fixed Heat (60°C) & Electrochemical Carbon Monoxide
Power Source:	220-240v AC 50Hz
Backup Power Source:	Lithium Battery with 10-year Life
Approved/Manufactured To:	BS 5446-2:2003 and BS EN 50291-1:2018
Designed For Installation To:	BS5839-6:2019 and BS EN 50292:2023
CO Alarm Activation Threshold:	50ppm (60-90mins), 100ppm (10-40mins), 300ppm (<3 mins)
Alarm Sound Level:	85db at 3m
Ambient Operating Temp:	0°C to 40°C
Ambient Operating Humidity:	10% to 90%
Power Consumption (In Alarm):	≤40mA
Power Consumption (Standby):	≤10µA
Min/Max Cable CSA:	0.75mm ² to 1.5mm ²
LED Indicator Function:	Green = Mains Power, Red = Battery/Fault Status
Warranty:	5 years
Max Interconnected Units:	20
Max Hardwire Interconnect Distance:	150m
Max RF Connected Units:	20
Max RF Distance:	Open Area 80m, Enclosed Area 30m
Backup Battery Life (No Mains):	30 days
Storage Temperature:	-10 to 50°C
Storage Humidity:	0 to 90% (non-condensing)

HSSA/HCO/10 (FULL UNIT) & HSSA/HCO/10H (HEAD ONLY)

HEAT AND CARBON MONOXIDE ALARM



INSTALLATION LOCATIONS:



Kitchens



Garages



Loft Extensions



Gas Boilers



Gas Fireplaces

PRODUCT CONSTRUCTION:

Plastic Housing Material:
Fire Retardant ABS

Weight (Unboxed):
255g (Head – 170g)

Cable Entry:
Rear Entry and Side
(mini-trunking) Knockout

LINE DRAWINGS:

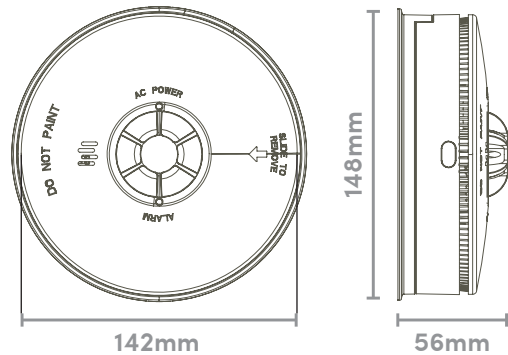

HEAT
KM 792789
BS 5446-2:2003

CO
KM 792791
BS EN 50291-1:2018



5 YR
GUARANTEE

*All information is subject to change and should be verified before any critical action.

01257 262 197 customerservices@hispec.co.uk hispec.co.uk



Hispec Electrical Products Ltd, Unit 21 Drumhead Road, Chorley North Business Park, Chorley, PR6 7BX