

## Lexicomm Solo EVCS Master Station

### Cable Key

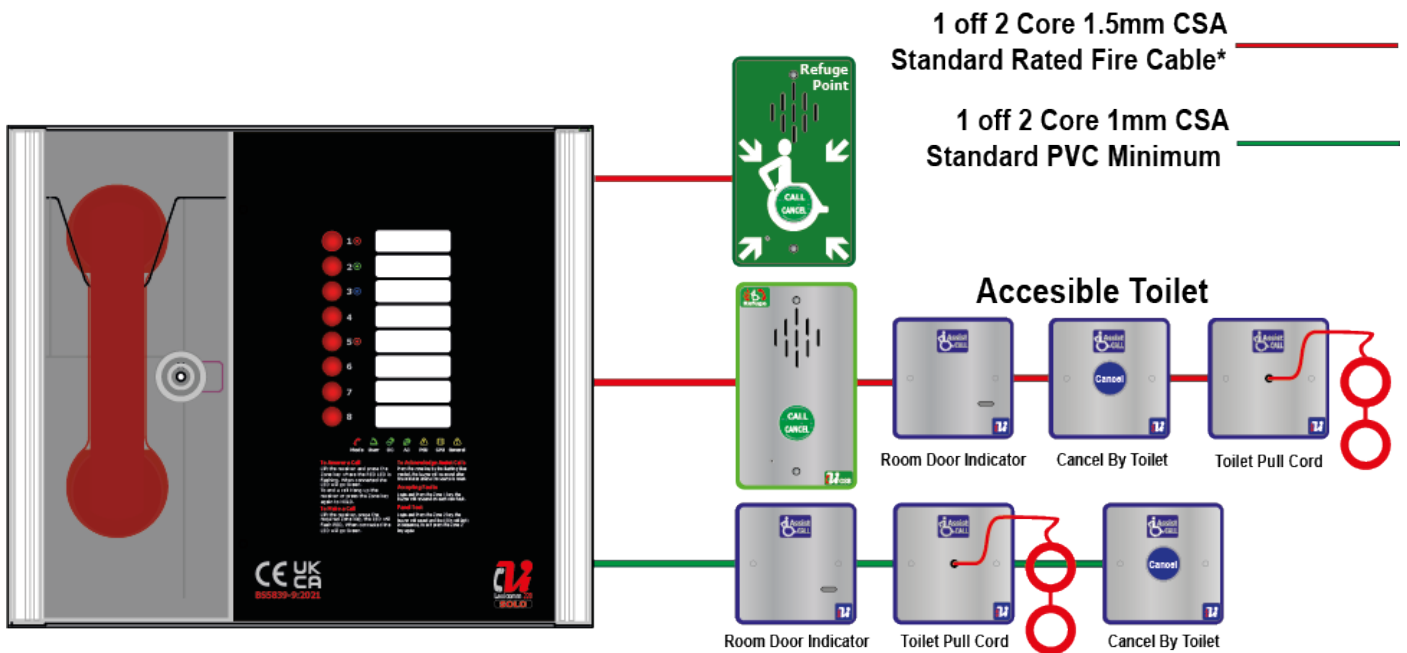

## Installation and Commissioning Manual Revision 2 – January 2025

**Document Control**

Revision	Description of Change	Date of Change	Author of Change
0	Initial Draft/ Release		JS
1	Relay changes, Mode LED changes, indicator changes	02.02.23	JK
2	Updated layout	19.11.24	JS

## Table of Contents

<b>1 Introduction</b> .....	<b>3</b>
1.1 What is an Emergency Voice Communication System?.....	3
1.2 Suitability.....	3
<b>2 Product Overview</b> .....	<b>3</b>
<b>3 Important Safety Information</b> .....	<b>4</b>
<b>Anti-static handling guidelines</b> .....	<b>4</b>
3.1 Battery Information .....	4
<b>4 Unpacking the Unit</b> .....	<b>5</b>
<b>5 Installation</b> .....	<b>6</b>
5.1 Connecting the ViLX-228S Master Station.....	7
5.2 Planning the Wiring .....	7
5.3 Cable and Wiring Guidance .....	7
5.4 Mains Connection .....	8
5.5 Battery Information .....	8
5.6 Outstation Connections.....	9
5.7 Auxiliary Connections.....	11
5.8 Powering up procedure.....	11
5.9 Powering down procedure .....	11
<b>6 Set up procedure</b> .....	<b>12</b>
6.1 ViLX-228S Master Station Display PCB Dipswitch Settings .....	12
6.2 Exchange PCB Diagram- .....	13
6.3 Adding a Line Card .....	13
6.4 Removing a Line card .....	13
<b>7 System Menus</b> .....	<b>13</b>
7.1 Login Procedure .....	13
7.2 Fault Accept.....	13
7.3 Panel Indicator Test .....	14
7.4 Extended Fault Menu .....	14
7.5 Remote Signal Delay Timer .....	14
7.6 In Use Relay Options .....	14
<b>8 Operation</b> .....	<b>15</b>
8.1 Receiving a Call.....	15
8.2 Making a Call .....	15
8.3 Ending a Call.....	15
8.4 Putting a Call on Hold .....	15
8.5 Conference Call .....	15
8.6 Acknowledging "Assist Call" Alarms .....	15
8.7 Accepting Faults.....	16
8.8 Panel Indicator Test .....	16
<b>9 Indications and Controls</b> .....	<b>16</b>
9.1 Mode Indicator Summary.....	16
9.2 Power supply and CPU indicator Summary .....	17
9.3 User Indicator Summary .....	17
9.4 Zone indicator summary .....	17
<b>10 Commissioning procedure</b> .....	<b>18</b>
10.1 Cable Checks.....	18
10.2 Set up, power up.....	18
10.3 Intelligibility Tests .....	18
10.4 Assist Call Checks .....	18
<b>11 Maintenance</b> .....	<b>18</b>
<b>12 Outstation zone template</b> .....	<b>19</b>
<b>13 Technical Specification</b> .....	<b>21</b>

# 1 Introduction

## 1.1 What is an Emergency Voice Communication System?

An Emergency Voice Communication System, or EVCS, is a system that allows voice communication in either direction between a central control point and several other points throughout a building or building complex, particularly in a fire or emergency. The control points, or outstations by which they are more commonly referred, generally comprise of a Type A outstation, a Type B outstation, or a Type C Combined Type outstation. "Assist Call" emergency assistance alarm systems can also be incorporated into the EVCS.

EVCS is generally required in the following situations:

- In any building or sports or similar venue where there are disabled people, or people who may have difficulty negotiating the evacuation route.
- In buildings with phased evacuation and/or firefighting lifts where it facilitates secure communications for building managers, fire wardens, and attending fire officers.
- At sports venues and similar complexes, where it will assist stewards in controlling the evacuation of the area in an emergency.

The Lexicomm ViLX-228S Emergency Voice Communications System (EVCS) is designed to fully comply with BS 5839-9:2021 for use as a Fire Telephone system, Disabled Refuge system or as a combined system when both Fire Telephones and Disabled Refuge Points are required.

## 1.2 Suitability

Fire telephone systems are recommended for all public buildings and multi-story buildings over four floors that require phased evacuation as per BS 9999:2017.

Disabled Refuge systems are required in buildings where the public or staff gains access to any floor other than the ground floor using lifts. A refuge is a relatively safe waiting area provided at each storey exit from each protected stairway.

Refuge areas are not just for wheelchair users, they are for anyone who may need assistance i.e. someone who's immediate evacuation will impede the egress of others, a pregnant woman over 6 months term or persons with long term injuries, arthritis etc.

## 2 Product Overview

The Lexicomm EVCS, or ViLX-228S, comprises of a Master Station and one or more outstations. Additionally, the "Assist Call" emergency assistance alarm system can either be connected to the same line as a Type B outstation or connected to a dedicated line. Neither the outstations nor the "Assist Call" emergency alarm system require a separate power supply unit as each line is powered from the Master Station. This has the additional benefit of each line being fully monitored and battery backed up.

The ViLX-228S Master Station has been designed for radial star topology. In most cases this will reduce the cable requirements for all ring-based systems. The topology consists of spurs formed of 1 off two core 1.5mm CSA cables (soft skin enhanced up to 500m per leg, MICC 200m per leg) to each outstation.

### 3 Important Safety Information

This Equipment must only be installed and maintained by a suitably skilled and competent person.

This Equipment is defined as Class 1 in EN IEC62368-1:2020+A11:2020 and must be EARTHED.



Caution



Indoor Use Only



Warning

Shock Hazard-  
Isolate Before Opening

Warning

TO REDUCE THE RISK OF FIRE OR ELECTRIC SHOCK, DO NOT  
EXPOSE THIS UNIT TO RAIN OR MOISTURE

Warning

THIS UNIT MUST BE EARTHED

Warning

NO USER SERVICEABLE PARTS

Each ViLX-228S Master Station requires local isolation with verification as per the Electricity at Work Regulations 1989, returning to a B6A breaker clearly marked "**EMERGENCY VOICE COMMUNICATION SYSTEM. DO NOT TURN OFF**".



#### Anti-static handling guidelines

Make sure that electrostatic handling precautions are taken immediately before handling PCBs and other static sensitive components.

Before handling any static-sensitive items, operators should get rid of any electrostatic charge by touching a sound safety earth. Always handle PCBs by their sides and avoid touching any components.

#### 3.1 Battery Information

In the event of mains failure BS 5839-9:2021 requires battery backup for 24 hours standby and 3 hours operation thereafter.

A ViLX-228S Master Station requires local isolation with verification as per the Electricity at Work Regulations 1989, returning to a B6A breaker clearly marked "**EMERGENCY VOICE COMMUNICATION SYSTEM. DO NOT TURN OFF**".

A ViLX-228S Master Station requires **one number** 12V 7AH vent regulated sealed lead acid battery. The battery is not supplied with the ViLX-228S Master Station.



##### Safety Information:

Sealed Lead Acid batteries contain sulphuric acid which can cause burns if exposed to the skin. The low internal resistance of these batteries mean large currents will flow if they are accidentally short-circuited causing burns and a risk of fire.

*Exercise caution when handling batteries.*

##### Power Up Procedure:

Always apply mains power before connecting batteries.

When connecting batteries, always connect the Positive (Red +) terminal first.

##### Power Down Procedure:

Disconnect the batteries before removing the mains power.

When disconnecting batteries, always remove the Negative (Black -) terminal first.

**Battery leads should be removed by grasping the plastic battery spade connector covers not the red and black wires as this can cause premature failure of the lead.**

## 4 Unpacking the Unit

Remove the ViLX-228S Master Station from its packing, and check the contents against the following list:

- ViLX-228S Master Station.
- Quick start guide.
- Accessory pack with the following contents: -
  - 1 number 2.5mm AF Hex Key.
  - 1 number door handle/key.
  - End of Line (EoL) Resistors, 2 per line card



Figure 1

Use the 2.5mm AF Hex Key supplied to open the right-hand front cover.

Verify the following items are present:

- Correct number of Line Card, depending on configuration. c/w 2-way line connectors.
- 1 number 3-way mains connector.
- 1 number 2-way Fault connector.
- 1 number 2-way In Use connector.
- 1 number 2-way Enable connector.
- 1 number Battery lead.

If there are any items missing, please contact your supplier or Vox Ignis Limited, quoting the unit serial number and the name on the packing list enclosed, so the situation can be rectified.

# 5 Installation

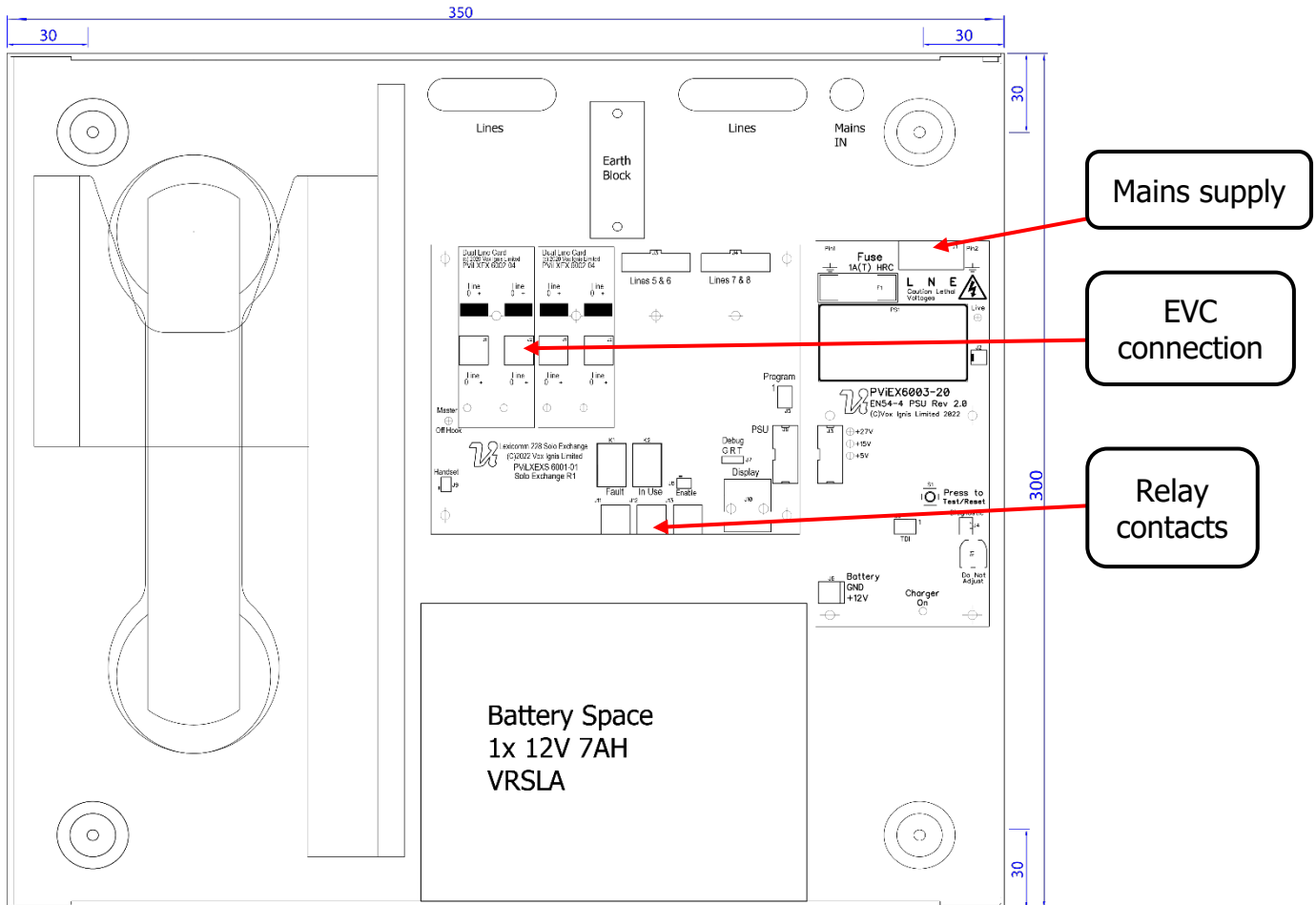

**Figure 2**

Prior to mounting the ViLX-228S Master Station, it should be decided if the field wiring is to be run on the surface or concealed. There are 14 knockouts on the top and 2 slotted entries with a dedicated mains supply entry at the rear. If a knockout is removed by mistake, fill the hole with a good quality cable gland.

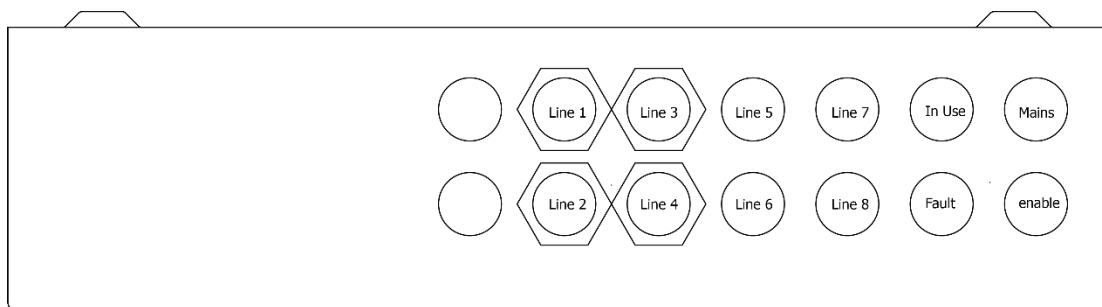

**Figure 3**

Unused knockouts must be left unopened to comply with the Low Voltage Directive. Accidentally knocked out holes should be blanked off.

The ViLX-228S Master Station weighs 6kg with batteries, so care should be taken to securely mount the Station on stud walling.

## 5.1 Connecting the ViLX-228S Master Station

To comply with EMC (Electro Magnetic Compatibility) regulations and to reduce the risk of electrical interference in the system wiring, the use of fire-resistant screened cables is recommended throughout the installation.

All wiring should come into the enclosure via the knockouts provided and be fixed tidily to the relevant terminals.

Note that correct cable glanding is essential. Due regard should be paid to any system specifications which demand a certain cable type, providing it meets the appropriate national wiring regulations.

## 5.2 Planning the Wiring

All system wiring should be installed to meet the appropriate parts of BS5839 Part9:2021 and BS 7671 (Wiring Regulations). Other national standards of installation should be adhered to where applicable.



**Do not test wiring using an insulation tester (Megger) with any equipment connected, as the 500 Volt test voltage will destroy these devices.**

You must observe local wiring regulations. Do not run SELV and LV cables in the same enclosure without adequate insulation between them.

## 5.3 Cable and Wiring Guidance

### 5.3.1 Fire Telephone system

Any system for use as a fire telephone system should use Type A outstations and must use enhanced grade cabling throughout for all wiring, including the mains supply to the ViLX-228S Master Station.

### 5.3.2 Disabled Refuge EVC System

For buildings less than 30m in height, or any building with sprinklers fitted, standard grade fire resistant cable may be used to wire Type B outstation and the mains supply to the Master Controller if the planned evacuation will be completed in 30 minutes.

If the building is over 30m in height without sprinklers, or where the evacuation will take place over multiple stages exceeding 30 minutes, then enhanced grade cables must be used.

### 5.3.3 Combined Systems

Cabling to Type A or Type C outstations must be in enhanced grade fire resistant cabling.

Individual spurs to Type B outstations can be wired in standard grade fire resistant cabling in accordance with the wiring guidelines already set out for disabled refuge systems.

### 5.3.4 "Assist Call" Emergency Assistance Alarm Systems

All installations must conform to Building Regulations Approved Document M. The "Assist Call" is wired using 2 core cable, and the "Assist Call" plates can be wired in any order.

### 5.3.5 Cabling methods

There are 3 cabling methods available:

- Connection to a Type A or Type C outstation: use 2 core enhanced grade fire resistant cable when extending a firefighting telephone system.
- Connection to a Type B outstation: use 2 core standard grade fire resistant cable when extending a disabled refuge system.
- Connection to an "Assist Call" system on a dedicated line requires 2 core 1mm CSA or above PVC sheathed.

### 5.3.6 ViLX-228S Master Station Wiring

The wiring for a ViLX-228S Master Station is shown in the schematic below.

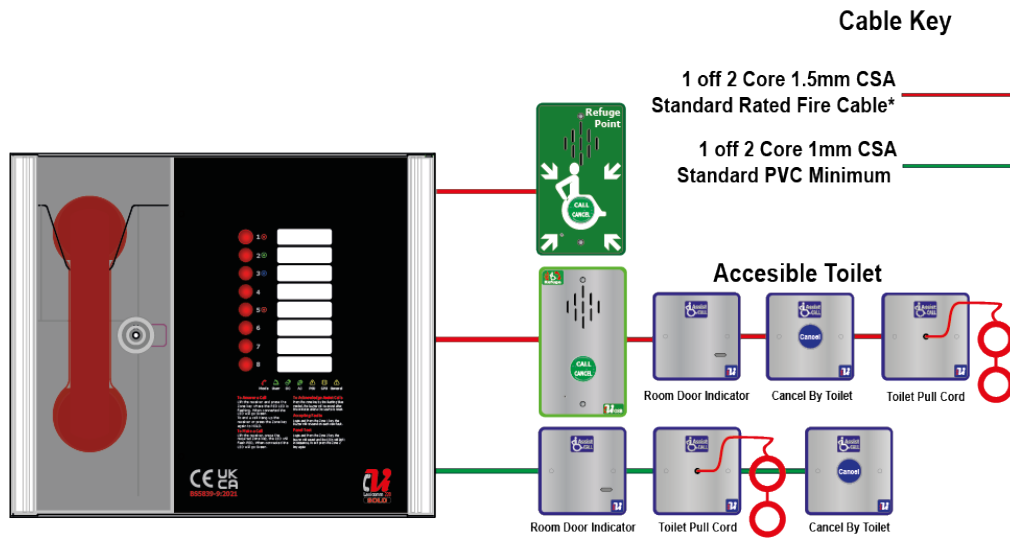

Figure 4

### 5.4 Mains Connection

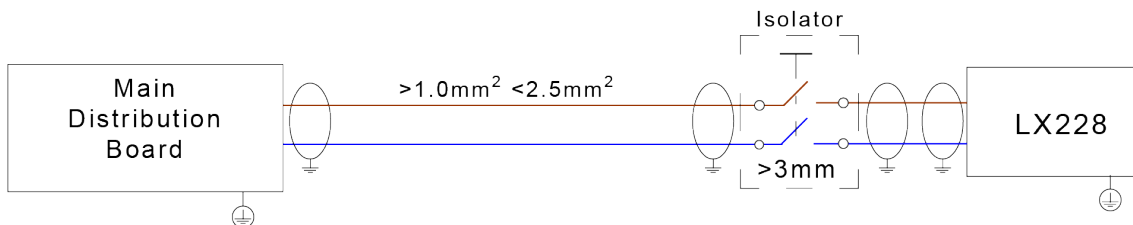

Figure 5



Each ViLX-228S Master Station requires local isolation with verification as per the Electricity at Work Regulations 1989, returning to a B6A breaker clearly marked **"EMERGENCY VOICE COMMUNICATION SYSTEM. DO NOT TURN OFF"**.

### 5.5 Battery Information

In the event of mains failure BS 5839-9:2021 requires battery backup for 24 hours standby and 3 hours operation thereafter.

A ViLX-228S Master Station requires **one number** 12V 7AH valve regulated sealed lead acid battery. The battery is not supplied with the ViLX-228S Master Station. Vox Ignis recommend a Yuassa NP7-12



#### Safety Information:

Sealed Lead Acid batteries contain sulphuric acid which can cause burns if exposed to the skin. The low internal resistance of these batteries mean large currents will flow if they are accidentally short-circuited causing burns and a risk of fire.

*Exercise caution when handling batteries.*

#### Power Up Procedure:

Always apply mains power before connecting batteries.  
When connecting batteries, always connect the Positive (Red +) terminal first.

#### Power Down Procedure:

Disconnect the batteries before removing the mains power.  
When disconnecting batteries, always remove the Negative (Black -) terminal first.

**Battery leads should be removed by grasping the plastic battery spade connector covers not the red and black wires as this can cause premature failure of the lead.**

## 5.6 Outstation Connections

The ViLX-228S Master Station is equipped with at least one number Dual line card. One outstation per line output can be connected. If no outstation is connected to the line output, then an end of line 10kΩ resistor should be fitted. The dipswitch located on the rear of the door mounted Display PCB is used for configuration see 6.1

The following devices are available on the system:

- Type A (fixed phone)
- Type B (hands-free refuge point)
- Type C "Combi" (combined Type A and Type B)
- Jack point
- "Assist Call" emergency assistance alarm system

For Type A, and Type C outstations the end-of-line 10kΩ resistor is not required as it is integral to the product. For Type B outstations the end-of-line 10kΩ resistor should be removed from the accessory pack and connected to the end-of-line terminal in the outstation.

For Jack points and the "Assist Call" system, the end-of-line 10kΩ resistor should also be removed from the accessory pack and connected to the last plate on the system.

### 5.6.1 Type A outstation

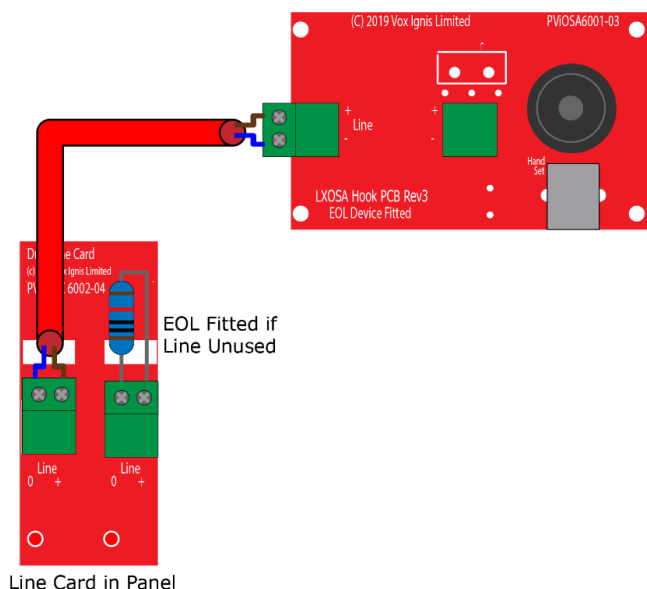

**Figure 6 - Type A/C Outstation Connections**



**Note:** The Earth screen should be sleeved and connected to the terminal block in the controller, and the earth stud in the Type A outstation.

## 5.6.2 Type B outstation

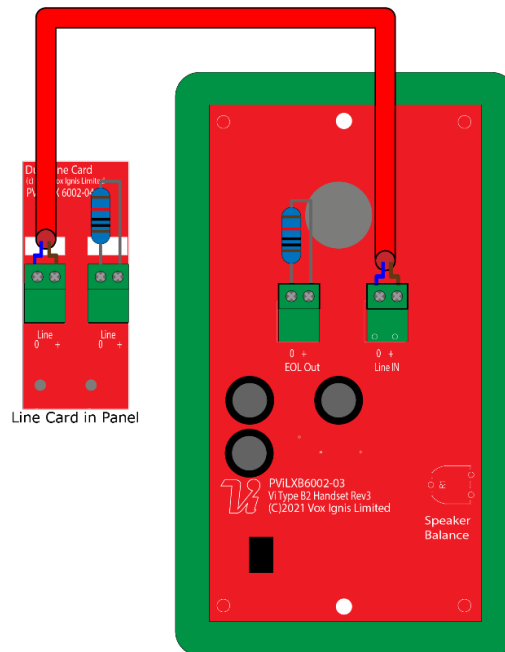

Figure 7 - Type B Outstation Connections



**Note:** The Earth screen should be sleeved and connected to the terminal block in the controller, and the earth connection in the metal back box (if a plastic back-box is used cut the earth back and insulate at the outstation).

## 5.6.3 ACA Accessible Toilet Kit

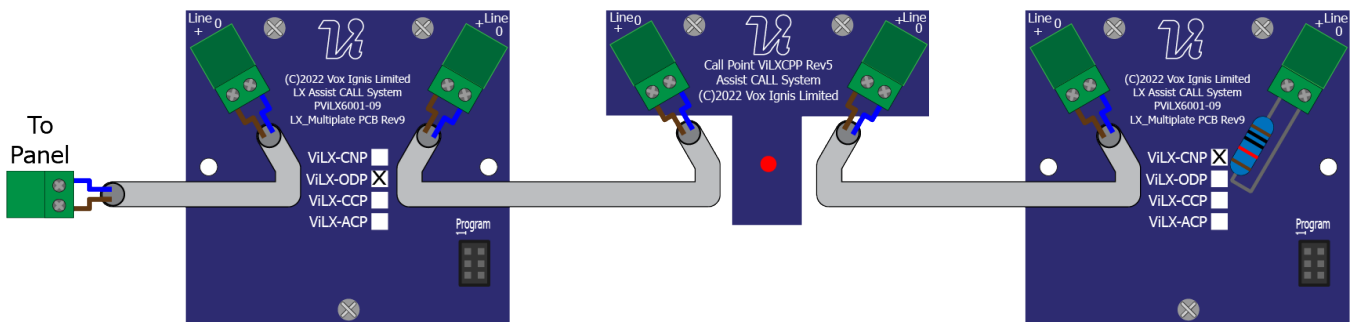

Figure 8 - Assist Call Accessible Toilet Kit Connections

The "Assist Call" ACA kit comprises an Over Door Indicator, a Pull Cord, and a Cancel Plate. The above order is a typical order; with the Over Door Indicator, Pull Cord and the Cancel Plate connected as shown, but the plates can be wired in any order, as long as the EOL resistor goes into the free terminal of the last plate.

## 5.6.4 Accessible Toilet connection via Type B outstation

It is possible to connect the Assist Call ACA Kit to the Vox ignis Type B outstation. The kit is connected as shown in **Error! Reference source not found.**, it is connected to the EOL Out terminal. It must be wired using the same integrity cable as the type b outstation to meet BS 5839-9:2021.

**Note We do not recommend this connection method in schools or similar premises where it is likely the disabled refuge system is isolated until the fire alarm system is activated. For further information see Technical Bulletin VITB-002.**

### 5.6.5 Fire telephone jack type connection

The system is fully compatible with Vox Ignis range of jack points and roaming phones. Connections for standard ViLX-OSJ jack points



Figure 9

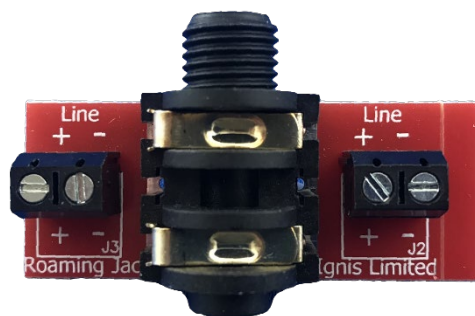

Figure 10

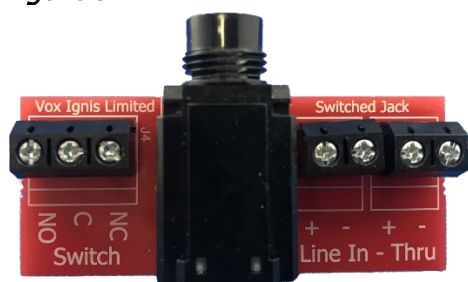

Figure 11

Connections for ViLX-OSJ-S jack point with switch contact output. There are 2 x sets of terminals for In and Out connections, the wiring is polarity conscious.

### 5.7 Auxiliary Connections

The 228S has three auxiliary connections:

**Fault** is a normally CLOSED volt free relay (30V DC 1A) which OPENS on any fault on the network, including loss of power

**In Use** is a normally OPEN volt free relay (30V DC 1A) connection. The relay CLOSES when configured to do so by the TMS3 (see **Error! Reference source not found.**), usually when an outstation on the network is operated

**Enable** is a normally CLOSED input, and is required to operate the system, this is often connected to the fire alarm system. If Jumper J8 is in place, then no connection is required at the terminals.

**It is advised that this feature is not used as the system should always be available, not just during an evacuation.**

If this function is used, then the removal of Jumper J8 and opening the **Enable** input, will not display incoming calls from Type B outstations only. Calls from Type B outstations automatically "time out" after approximately 30 minutes. Type A outstations and "Assist Call" emergency assistance alarm systems will continue to operate. If this feature is utilised, then the mode LED illuminates yellow after 30 seconds to show that the system is disabled.

**Note:** If the system is disabled, the master station can still make outgoing calls.

If this function is used, it only requires connection with one panel on the network. If the **Enable** input is CLOSED on one panel, then all panels on the network are CLOSED. To disable Type B outstations, then the **Enable** input on all panels on the network must be OPEN.

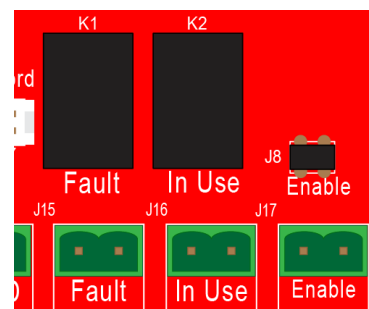

Figure 12 - Lexicomm Auxiliary Connections

### 5.8 Powering up procedure

To power up the ViLX-228S Master Station, carefully check all internal wiring before applying mains power to the ViLX-228S Master Station. Once the ViLX-228S Master Station is powered, the battery can be attached using the battery leads supplied. When attaching the battery, always attach the Positive (Red+) terminal first.

### 5.9 Powering down procedure

To power down the ViLX-228S Master Station, first disconnect the battery. Always disconnect the Negative (Black -) terminal first. Once the battery leads have been disconnected, then remove mains power.

## 6 Set up procedure

The ViLX-228S Master Station has various site configurations which are configured using the dipswitch located on the rear of the Display PCB.

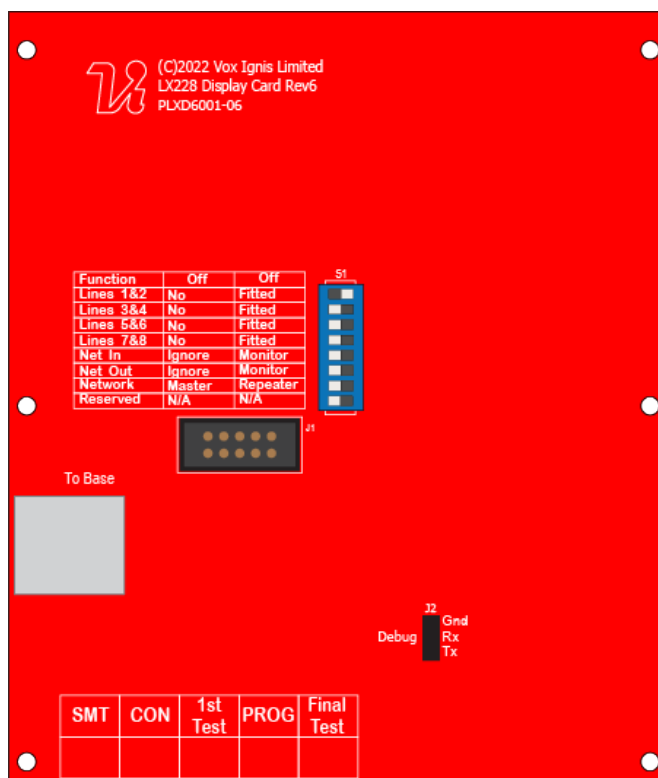

Figure 13

### 6.1 ViLX-228S Master Station Display PCB Dipswitch Settings

1	2	3	4	5	6	7	8	Remarks
Line 1&2	Line 3&4	Line 5&6	Line 7&8	NA	NA	NA	Reserved	
✓				NA	NA	NA		Line card 1 fitted
✓	✓			NA	NA	NA		Line card 1, 2 fitted
✓	✓	✓		NA	NA	NA		Line card 1, 2, 3 fitted
✓	✓	✓	✓	NA	NA	NA		Line card 1, 2, 3, 4 fitted

Table 1

✓ = Dipswitch in ON position  
x = Dipswitch in OFF position

## 6.2 Exchange PCB Diagram-

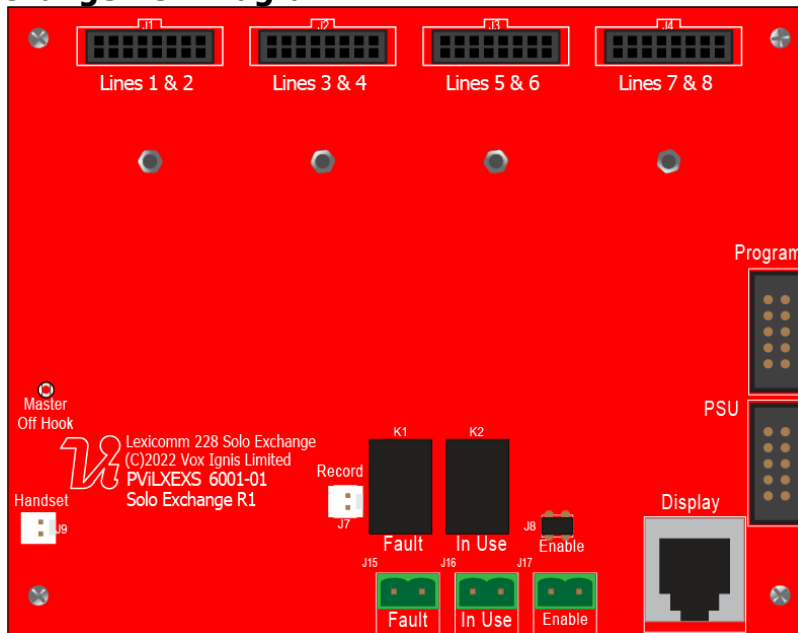

Figure 14 - Lexicomm Solo Exchange PCB Diagram

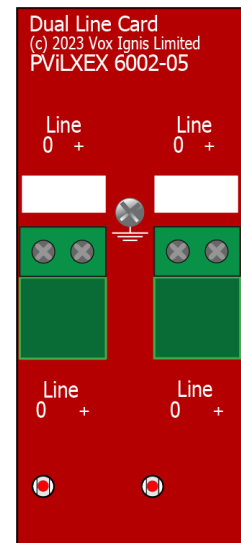

Figure 15 - Lexicomm Dual Line Card

## 6.3 Adding a Line Card

The ViLX-228S Master Station is supplied with at least **one number** Line Card. There are 2 lines per Line Card. Before adding a Line Card, ensure that the ViLX-228S Master Station is not powered. If the ViLX-228S Master Station is powered, then power down the ViLX-228S Master Station (see 5.9).

To fit the Line Card:

1. Place Line Card in the next available space on the Exchange PCB and secure using the supplied screw.
2. Remove the line terminal and connect the field wiring.
3. Push the terminal into the correct position on the Line Card.
4. Set the dipswitch on the Display PCB (see 6.1) to enable Line Card monitoring.

Once the Line Card is securely fitted, power up the ViLX-228S Master Station (see 0).

## 6.4 Removing a Line card

Before removing a Line Card, ensure that the ViLX-228S Master Station is not powered. If the ViLX-228S Master Station is powered, then power down the ViLX-228S Master Station (see 5.9).

To remove the Line Card:

1. Remove all line terminals from the Line Card that is to be removed.
2. Remove the securing screw.
3. Remove the Line Card from Exchange PCB.
4. Set the dipswitch on the Display PCB (see 6.1) to disable Line Card monitoring.

Once the Line Card has been removed, the ViLX-228S Master Station may be powered (see 0).

## 7 System Menus

### 7.1 Login Procedure

For access level 2 (User) the code is 1664, for access level 3 (Engineer) the code is 1812. Enter the relevant code using the numbered buttons 1-8, as each button is pressed the user LED will flash cyan/magenta faster until the required code is entered, at which point LEDs 1-3 will illuminate cyan for User mode and LEDs 1-5 will illuminate magenta for Engineer mode.

### 7.2 Fault Accept

Before accepting faults, the fault must be noted in the logbook, along with the time the fault was reported.

To accept the fault, enter either the access level 2 (code: 1664) or access level 3 (code: 1812) menu, then press zone button 1. The buzzer will silence, and the general fault LED will now go steady.

Press zone button 8 to exit this menu and to return to the menu options.

The buzzer will resound on each new fault and after 8 hours.

### 7.3 Panel Indicator Test

To test the panel indicators, enter either the access level 2 (code: 1664) or access level 3 (code: 1812) menu, then press zone button 2.

All LEDs will illuminate in a predefined sequence, and the buzzer will sound.

Press zone button 8 to stop the panel indicator test and to return to the menu options.

### 7.4 Extended Fault Menu

Enter the access level 2 code (1664) or access level 3 (code: 1812) then press zone button 3.

Zone	Indicator Status	Description
1-4	Blank	Line card configured as not fitted
	Yellow Solid	Line card configured as fitted but not present
	Green Solid	Line card configured as fitted and present
5	Not Used	
6	Not Used	
7	Green Solid	Display Processor Healthy
	Yellow Solid	Display Processor Fault
8	Green Solid	Exchange Processor Healthy
	Yellow Solid	Exchange Processor Fault

Table 2

### 7.5 Remote Signal Delay Timer

The in-use relay, function can be altered to provide a remote signal via an auto dialler, BMS or similar. The delay is adjustable between 30 seconds and 3 minutes such that if a call from an outstation is not answered within the chosen time delay, then the relay operates. This could be used to send a signal off site during periods when the master station is not attended.

If the call is answered during the delay period, the relay will not operate, and the timer will cease.

The above function works identically with the Assist Call emergency assistance system.

Enter the access level 3 code (1812), then press button 4 to enter this mode. The magenta zone indicators from 1 to 8 will be illuminated depending on selection, pressing button 2 will give a 30 second delay, button 3 a one-minute delay and so on to button 7 which gives a three minute delay. When the required delay is selected, the adjacent indicator will illuminate to confirm the delay period. Press button 8 to exit this mode.

Button	Delay Timer Options
1	No Delay
2	30 Secs
3	1 Min
4	1 min 30 secs
5	2 min
6	2 min 30 secs
7	3 min
8	Exit

Table 3

### 7.6 In Use Relay Options

The in-use relay has programmable functions which can work in tandem with the delay timer described in 0. These functions can provide a relay output as described in the table below:

These relay functions can be useful for providing an output of specific system operation of EVC, Assist Call or both.

This relay can also be used to connect to the ViLX-RAP Remote Alarm panel or a remote sounder or beacon which can be configured to cancel operation when the master handset is picked up such that the sounder will not interfere with the conversation.

Enter the access level 3 code (1812), then press button 5 to enter this mode. The magenta zone indicators from 1 to 8 will be illuminated depending on selection. When the required selection has been made press button 8 to exit this mode.

Button	Relay Option
1	Not Used
2	EVCS & Assist Call
3	EVCS only
4	Assist Call Only
5	Relay activates on EVC call connection conversation only.
6	Relay activates on any call, Relay de-energises on master handset pickup
7	Relay operates when call not answered /acknowledged (EVCS and Assist Call)
8	Exit

*Table 4*

## 8 Operation

All conversations are under the command of the ViLX-228S Master Station.

### 8.1 Receiving a Call

One of the eight zone LEDs and the mode LED will flash red to indicate an incoming call. The flash rate will identify the outstation type, with a Type A outstation having a faster flash rate than a Type B outstation.

Lift the Master handset receiver. The User LED will illuminate Red.

Press the corresponding zone button (indicated by the red flashing LED). This LED and the User LED will change to flashing green to show that this line is now connected, and a conversation can take place.

### 8.2 Making a Call

To make a call, lift the Master handset receiver and the User LED will illuminate red.

Press the zone button for the required outstation. The corresponding zone LED will flash red. This flash rate will be slower than the flash rate for either an incoming Type A or Type B call.

When the outstation answers the call, the zone LED flashes green, the mode LED illuminates red and the user flashes green to indicate this line is now connected and a conversation can take place.

### 8.3 Ending a Call

To end the call from the outstation, either replace the Type A receiver back on its hook or press the call/cancel button for a Type B outstation.

To end a conversation from the ViLX-228S Master Station, replace the Master handset receiver back on its hook.

Note: This will not end the call, only the conversation. The outstation will revert back to requesting a call, and the zone LED will flash red to indicate this. The call MUST be ended at the outstation.

### 8.4 Putting a Call on Hold

To put a call on hold, press the zone button to select outstation that is already connected. The zone LED will change from flashing green to flashing green/red. The user LED also flashes green/red and the mode LED.

To reconnect the call, press the zone button for the required outstation again. The zone LED will change from flashing green/red to flashing green to indicate the call is now connected again.

### 8.5 Conference Call

Depending upon the number of Line Cards fitted in the ViLX-228S Master Station, up to five lines can be connected to the conference call at any one time. To receive a call, see 8.1. To make a call to an individual outstation, see 8.2. The ViLX-228S Master Station controls which lines are involved in the conference, and only one conference group is allowed.

### 8.6 Acknowledging "Assist Call" Alarms

When an "Assist Call" goes into alarm, the appropriate zone LED will flash blue, and a two-tone buzzer sounds to indicate that an "Assist Call" alarm has been operated.

To acknowledge the alarm, press the corresponding zone button, and the blue LED will illuminate continuously with an intermittent buzzer tone every 15 seconds. If after 2 minutes the "Assist Call" alarm has not been cancelled, the buzzer will resound, and the LED will flash blue.

Within the WC cubicle the pull cord indicator will change from continuous indication to no indication. The cancel plate will alter from flashing to continuous and the buzzer will change from continuous to intermittent. Outside the cubicle the Over door plate indication will alter from flashing to continuous and the buzzer will change from continuous to

intermittent. This change in indication and buzzers during the acknowledge phase indicates to the WC user that help is on the way.

### 8.7 Accepting Faults

Before accepting faults, the fault must be noted in the log book, along with the time the fault was reported. To accept the fault, enter either the access level 2 (code: 1664) or access level 3 (code: 1812) menu, then press zone button 1. The buzzer will silence, and the general fault LED will now go steady. Press zone button 8 to exit this menu and to return to the menu options. The buzzer will resound on each new fault.

### 8.8 Panel Indicator Test

To test the panel indicators, enter either the access level 2 (code: 1664) or access level 3 (code: 1812) menu, then press zone button 2. All LEDs will illuminate in a predefined sequence, and the buzzer will sound. Press zone button 8 to stop the panel indicator test and to return to the menu options.

## 9 Indications and Controls



Figure 16

### 9.1 Mode Indicator Summary

Mode	Description
Green solid	Normal state
Red solid	Outstation off hook
Blue solid	Assist call active
Yellow Solid	Refuge (type B) points disabled
Flashing Red/Blue	Incoming call/ Assist Call alarm at same time
Flashing Yellow	Fault on system

Table 5

## 9.2 Power supply and CPU indicator Summary

AC	DC	PSU	General	CPU	Description
✓					Mains OK
x		Flash	Flash		Mains failure
✓	✓				Battery OK
✓	x	Flash	Flash		Battery open circuit
✓	x	✓	Flash		Battery short circuit
✓	Flash	✓	Flash		Battery high impedance
✓		✓	Flash	✓	PSU processor fail
✓			Flash	✓	Display or Exchange Processor Fault or Display-Exchange comms fault, refer to 7.4 Extended Fault Menu
✓			Flash		Display or Exchange Processor Fault or Display-Exchange comms fault refer to 7.4 Extended Fault Menu

**Table 6**

✓ = LED illuminated

x = LED off

Flash= LED Flashing

**Note:** When faults are accepted the general LED illuminates solid.

## 9.3 User Indicator Summary

Red	Master handset off hook
Flashing Yellow	Master handset open circuit
Cyan	User logged in
Magenta	Engineer logged in
Flashing green	Call connected
Flashing Red/Green	Call on hold
Solid Yellow	Master handset short circuit

**Table 7**

## 9.4 Zone indicator summary

Zone Indicator Status	User Indicator Status	Buzzer Status	Description
Slow flash red		Off	Outgoing call
Fast flash red		Ringling	Incoming call from type A outstation
Normal flash red		Ringling	Incoming call from type B outstation
Normal flash green	Normal flash green	Off	Call connected to master handset
Normal flash green/red	Normal flash green/red	Off	Call on hold
Solid yellow		On	Line Short circuited
Slow flash yellow		On	Line card missing
Normal flash yellow		On	Line Open circuit or EOL missing
Fast flash yellow		On	Line Earth fault
Solid cyan	Solid cyan	Off	Access level 2
Solid magenta	Solid magenta	Off	Access level 3
Normal flash blue		2 Tone Alarm	Incoming Assist Call alarm
Solid blue		Intermittent double Beep	Assist call acknowledged

**Table 8**

## 10 Commissioning procedure

The commissioning should be carried out by a competent person who has a basic knowledge and understanding of the design and installation sections of BS 5839-9:2021 and has access to the specification of the project.

### 10.1 Cable Checks

The 500v insulation tests should have been carried out by the installer and the results made available to the commissioning engineer.

All cables should be correctly labelled.

Test field wiring and check for end-of-line 10kΩ resistor. Check cables are clear from any short or open circuits. Connect cables into Line Cards.

### 10.2 Set up, power up

Configure relevant dipswitches for the number of Line Cards fitted, these should have been factory set.

Power up the ViLX-228S Master Station using mains only, fed via a double fitted in an unswitched fused spur. The AC power indicator will be illuminated, and the DC power indicator is extinguished. The PSU fault and General fault indicators will be illuminated. There should be no line fault indicators illuminated.

If there are no line faults present, the battery may be connected. The DC power indicator will be illuminated, and the PSU fault and General fault indicators are extinguished when battery is connected.

If there are any line fault indicators illuminated, then the field wiring should be checked prior to the battery being connected.

### 10.3 Intelligibility Tests

Lift the master handset receiver and listen for a cadence tone.

An intelligibility test will need to be performed when the system is complete and the building has normal background noise levels. The intelligibility test requires two personnel.

One person should be present at the master station, the other person should visit each outstation in turn and put the outstation into call. The master station operator should check the location of the outstation is correct and have a conversation, the master station operator should then call the outstation back to check the reverse operation.

### 10.4 Assist Call Checks

Where Assist Call is fitted, all pull cords in each circuit should be tested, acknowledged at the panel, cancelled at the call location. Ensure all controls and indicators operate correctly.

## 11 Maintenance

It is a requirement of BS 5839-9:2021 that a maintenance agreement be in place for the EVCS. The maintenance schedule should be as follows:

Frequency	Test
Weekly	Test a different outstation on the system each week and make a call to the master station. Repeat each week until all outstations and master stations are tested. Record these results in the site log. *if more than one master station is present alternate weekly. Non EVC mode devices should also be tested for correct operation, at a frequency of at least 1 per week so that all devices are tested over a 12-month period.
Biannually	Engineer call to check system operation perform 100% outstation and master station operation, field strength of attached AFILS equipment and check battery health. Record results and any variations into the site Logbook.
5 Yearly	In addition to Yearly tests replace all batteries and record in Logbook.
	<i>Refer to BS 5839-9:2021 for full details of maintenance and testing requirements.</i>

## 12 Outstation zone template

There is space to the right of each outstation zone indicator to name the location of the outstation. At the rear of the display door there is a slot located in the centre above the display PCB; the outstation zone template can be inserted here.

The template is in "Word" format and can be downloaded at [www.vox-ignis.com](http://www.vox-ignis.com). Go to downloads section. This can be completed, printed out and cut to size as shown below.



TAB
Refuge 1 Name Toilet 1 Name
Refuge 2 Name Toilet 2 Name
Refuge 3 Name Toilet 3 Name
Refuge 4 Name Toilet 4 Name
Refuge 5 Name Toilet 5 Name
Spare 1
Spare 2
Spare 3

## Notes

# 13 Technical Specification

## DETAILS **ViLX-228S**

### POWER SUPPLY AND CHARGER

<b>AC Input</b>	230V AC $\pm$ 10% 50/60Hz
<b>Internal supply</b>	5V, 15V, 27V DC
<b>Supply and battery</b>	Monitored Open, Short, Fuses, High Impedance
<b>Protection</b>	Deep discharge, Short, Thermals
<b>Battery type</b>	1 $\times$ 12V 7AH VRSLA
<b>Mains fuse</b>	240V 1A HRC
<b>Battery fuse</b>	750mA PTC
<b>Max charge current</b>	400mA

### INPUTS

<b>Lines</b>	2-8 in 2 line blocks
<b>Remote enable</b>	Short to use
<b>End of line</b>	10k $\Omega$

### OUTSTATION CABLES

<b>Type</b>	Standard* / Enhanced
<b>Cores</b>	1 $\times$ 2 core radial 1mm or 1.5mm
<b>Distance</b>	500m from master station

### OUTPUTS

<b>Number</b>	2, Fault & In use
<b>Fault Relay</b>	1 $\times$ Volt free NC, Com 30V DC 1A

<b>In Use Relay</b>	1 $\times$ Volt free NO, Com 30V DC 1A
---------------------	--

### CONTROLS AND INDICATIONS

<b>Buttons</b>	8 Zone keys
<b>Zone LEDs (<math>\times</math>8)</b>	RGB Status LEDs
<b>Fault LEDs</b>	3: PSU, System, General
<b>Supply LEDs</b>	2: AC, DC present
<b>Status LEDs</b>	2: User & Mode RGB LEDs

### STANDARDS COMPLIANCE

<b>EMC</b>	EN 55035:2017+A11:2020 EN 55032:2015+A1:2020
<b>LVD</b>	EN IEC62368-1:2020+A11:2020
<b>Product Family</b>	BS 5839-9:2021, BS9999:2017, BS8300-2:2018

### DIMENSIONS

	<b>Panel</b>	<b>Bezel</b>	<b>Cut-out</b>
<b>Height</b>	300mm	350mm	305mm
<b>Width</b>	350mm	400mm	355mm
<b>Depth</b>	95mm	1mm	85mm
<b>Weight</b>	4.2kg		

\*Refer to BS 5839-9:2021 for exceptions

The Lexicomm ViLX-228S EVCS is designed and manufactured in the UK by:

Vox Ignis Limited  
Unit 27 NEBIC  
Enterprise Park East,  
Sunderland,  
SR5 2TA.  
Company Registration No: 8892407

[www.vox-ignis.com](http://www.vox-ignis.com)

[info@vox-ignis.com](mailto:info@vox-ignis.com)



WEEE  
Compliant  
Product

All information is believed to be correct at time of printing E&OE.  
Vox Ignis operate a policy of continuous improvement; always confirm specification details before purchase.  
Company Registration No: 8892407 [info@vox-ignis.com](mailto:info@vox-ignis.com)  
Document DVILX228S1003-02

