

CP4/AD/WP/PLUS



The Anti-Tamper and Weatherproof Enclosure for Addressable Manual Call Points

Rugged / Outdoor / Tamperproof Protection for Manual Call Points

Why use CP4/AD/WP/PLUS ?

The new 'All in One' protective enclosure specifically designed to give the added protection to vulnerable manual call points that is ultimately need.

Lead the fight back against environmental failure, vandalism or unnecessary damage.

These everyday issues can be a crippling cost to any business and potentially unrecoverable. Prevent downtime, eliminate false evacuations, save and protect your business and your life

CP4/AD/PLUS the protection designed to save lives

Application areas:

Industrial Areas, Outdoors Areas, Washdown Areas, Sauna's and Pool Areas etc....

Key attributes:

- Surface Mount (not retrofit)
- IP67 Weatherproof
- Break-Seal Mounting Area
- High Impact Protection (from both front & side)
- UV Stabilised (prolongs life from UV rays)
- Manufactured in Robust Polycarbonate



Strength & Durability

The CP4/AD/WP/PLUS is small, incredibly strong and robust, its construction helps to defend against 2 problematic false alarm issues. Firstly protecting the covering product from the ingress of water and dust especially if installation is within a harsh environment and secondly to defend the covering product against accidental or targeted misuse.

UV Stabilisation

Manufacture in UV stabilised polycarbonate it will become your first line of defence, having the ability to protect against extreme environmental conditions, hard hitting impacts from the front or from the side. Critically protecting essential life safety MCP's.

Product Dimensions in MM's

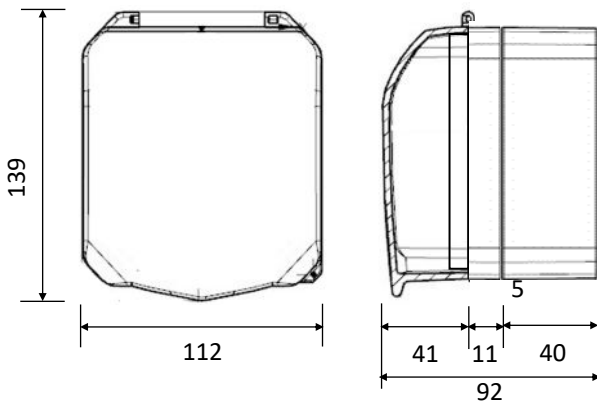

20mm Threaded Inserts



The rear back section has 20mm entry points on both the top and the bottom surfaces, giving you the ability to rotate the back box depending on the installation circumstances.

Operation Label

Comes complete with an fully instructive, translucent operation label. Easy to follow in case of an emergency or if legitimate activation is required



Additional Security Option—Break seal Facility

Deter unwanted access to the MCP and check for tampering. Attach a break-seal using the built in mounting holes positioned on the lower right hand corner of the cover and coloured central mounting chassis. The break seals are designed to be 'easy breaking' in case emergency access is actually required. **1 x Break-seal supplied with each product**

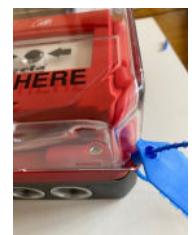

Accessories:

UG-BR-10 Ultra-Guard Replacement Break-seals, Pack of 10