



**Water Leak Detection  
Control Panel**

**Installation Instructions**  
**3500148\_REV0100**

# System Installation Notes

- Check design with the kit and components in hand to check that all materials are on site.
- Prepare the installation area. Remove any furniture or equipment that may obstruct installation. Make sure the area is clean and free from debris.
- Install all devices as per Product Installation Guides - these can be found via QR code on the product or via paper instructions.
- Test the complete system.
- Commission the system.
- Train the owner/operator.

## Panel Installation

### Safety

Suppliers of articles for use at work are required under section 6 of the Health and Safety at Work act 1974 to ensure as reasonably as is practical that the article will be safe and without risk to health when properly used.

An article is not regarded as properly used if it is used 'without regard to any relevant information or advice' relating to its use made available by the supplier.

This product should be installed, commissioned and maintained by trained service personnel in accordance with the following:

- (i) IEE regulations for electrical equipment in buildings
- (ii) Codes of practice
- (iii) Statutory requirements
- (iv) Any instructions specifically advised by the manufacturer

According to the provisions of the Act you are therefore requested to take such steps as are necessary to ensure that you make any appropriate information about this product available to anyone concerned with its use.

The control panel is designed to be operated from either 110V or 230V 50Hz mains supplies depending upon model and is of class 1 construction. As such it must be connected to a protective earthing conductor in the fixed wiring of the installation and a readily accessible double pole disconnect device meeting the requirements of EN60950/IEC950 which disconnects live and neutral simultaneously shall be incorporated in the fixed wiring. Switch disconnect devices such as MK Sentry 63A or similar are suitable for this.

**Failure to ensure that all conductive accessible parts of this equipment are adequately bonded to the protective earth will render the equipment unsafe.**

The control panel is designed for indoor use only and at temperatures between -50C (+/- 30C) and +400C (+/- 20C) and with a maximum relative humidity of 95%.

The IP rating for the enclosure is IP30.

Operation outside of these limits may render the equipment unsafe.

## Mechanical Data



The control panel should be mounted on a dry, flat surface, at eye height to the display and in a level position such that the enclosure is not distorted.

Screws or bolts of a minimum of 5mm diameter must be used to mount the enclosure in all three mounting positions.

It should be positioned in an accessible place as agreed with the end user. Suitable fixings should be used at all fixing points such that the control panel is securely mounted and is not liable to move once fixed.

The control panel should not be mounted in another enclosure or near sources of excessive heat.

Cables should be connected using suitable cable glands fitted to the knockouts provided. If additional cable entry points are required, all swarf and debris caused by drilling of additional cable entries must be cleared before power is applied to the panel.

## Cable Types

System wiring should be installed in accordance with National Standards and wiring regulations. To protect against electrical interference, we recommend the use of screened cables throughout the system. Separate cables should be used for sounder and detection circuits, the use of multi-core cables to carry sounder circuits and detector circuits is not recommended. The cable screen termination should only be connected to panel Earth points. The maximum cross section of cables to use is 2.5mm<sup>2</sup>, otherwise terminals in the control panel could be damaged. Mains wiring should be 3 core 1mm<sup>2</sup> to 2.5mm<sup>2</sup> fed from an isolating circuit breaker of 6A. This should be secure from unauthorized operation and be marked "Lockdown Alarm Do Not Switch Off". The mains supply must be exclusive to the fire panel.

## Technical Specification

PRIMARY SUPPLY VOLTAGE - IN	230 +10% -15% V AC
PRIMARY SUPPLY VOLTAGE- OUT	28.5V DC nominal
PRIMARY SUPPLY CURRENT-OUT	1.7 A @ 28.5V DC nominal (max.)
SECONDARY SUPPLY VOLTAGE	21.0 min. - 27.2 max. V DC - BAT charger o/p 28V DC
SECONDARY SUPPLY CURRENT OUTPUT	1.85 Amp maximum @ 20oC
INTERNAL BATTERY CAPACITY - MAXIMUM	2 x 12V x 7Ah Sealed Lead Acid Batteries
MAINS FUSE	4 A -250 V Slow Blow - 20 mm
BATTERY FUSE	1.85 Amp - Resettable
NUMBER OF DETECTION ZONES	2 / 4 / 8
ZONE CURRENT - QUIESCENT / ALARM	10 mA / 60 mA maximum
MAX. CABLE RESISTANCE / CAPACITANCE	40 Ohms / 0.470 uF
END OF LINE MONITORING	Active EOL - 10uF/50V Bipolar Capacitor
DEVICES PER ZONE	32 maximum - EN54 pt.2
ALARM RESISTANCE VALUE: INPUTS	270 - 1000 Ohms
MAXIMUM CURRENT: OUTPUTS	1A maximum current drive for both S1 & S2 circuits (500mA each)
VOLTAGE OUTPUT	27.5VDC nominal
END OF LINE RESISTOR: S1 & S2	S1 & S2: 10K Ohms - 1/4 Watt
AUXILIARY RELAY OUTPUT	1 Fire (COM-NC-NO) - 1 Fault (COM-NC) non-supervised
RELAY CONTACT RATING	30V DC - 2 Amp resistive loads
FULLY MONITORED INPUTS	Remote Activation, Remote Abort, Solenoid Status, Flow/Pressure Switch Status
EVACUATION AND RESET	Non-Latching - Voltage free contact
MAXIMUM HUMIDITY	95% RH Non-Condensing
PROTECTION RATING	IP30
OPERATING TEMPERATURE	-10°C to 50°C
WEIGHT	1.7 Kg - 7 Kg (inc. 2 x 7 AH 12 V bat.)
DIMENSIONS	273 (L) x 107 (W) x 404 (H) mm
COLOUR	White

# Cable Types

Before connecting zones or sounder cables, power up the control panel with the Active EOL connected to the zone inputs and the EOL resistors for the sounder/output lines connected. Then connect mains and battery power; there should be no fault indications. The mains supply should be routed away from the other cables and enter the control panel adjacent to the mains terminal block.

Depending on panel load and standby requirements, two 12-volt batteries of capacity up to 7Ah may be fitted in the housing (Fire Rated batteries are recommended.) The batteries should be wired in series (24V) using the supplied link. Take care not to short circuit the battery terminals.

Check zones, remote input and outputs wiring for continuity. Short or open circuit indications must be rectified before connecting to the control panel. All cable testing must be carried out with a Multimeter... **NEVER** use a Megger when devices are connected.

Transfer EOL components to the last device on detection zones and sounder/output circuits and connect the cables to their respective terminals in the control panel.

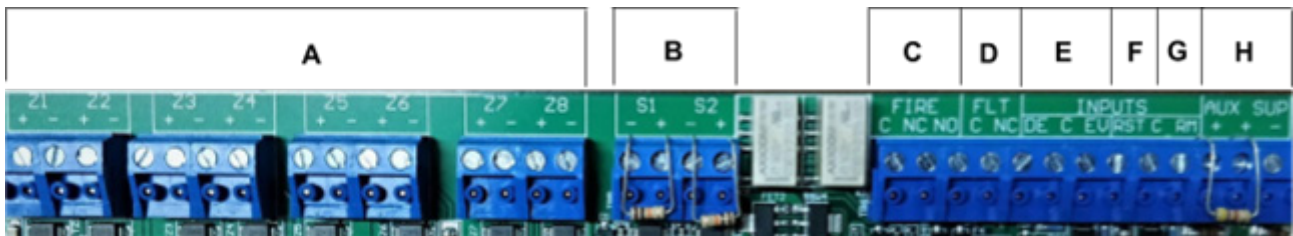

		Description	EOL
A	Z1 TO Z8	Water Leak Detection zones	CAP
B	S1, S2	Sounder Circuits	10K Res
C	FIRE RELAY	REL - Auxiliary Relay - Fire (Changeover)	N/A
D	FAULT RELAY	REL - Auxiliary Relay - Fault (Normally Closed)	N/A
E	INPUT DE +EV	Programmable Remote Inputs	N/A
F	RST	Remote Reset	N/A
G	RM	Disablement on Zone Remote Output Info	4K7
H	AUX SUP	Auxiliary Supply Outputs - 28 Vdc @ 300mA	N/A

# Operating and Programming the Panel

There are three access levels on the Identi-Cryer Control Panel:

## **LEVEL 1 – General User Controls**

- Perform LEDs and Buzzer test
- Silence Internal buzzer
- Put the panel into Access Level 2 or 3 using required access codes.

## **LEVEL 2 – Authorized user controls (2244) or Access Key**

- This level allows the user to:
- Silence and reactivate S1 and S2 sounder outputs
- Reset after an Alarm or Fault
- Manually activate the sounders (Evacuate function)
- Silence Internal Buzzer
- Disable/Enable: Outputs; Zones & Sounders;
- Activate/deactivate Delays

**NOTE:** When any zone or function is disabled, the Disabled LED on the STATUS area of the Control Panel display will be lit together with the corresponding function or zone disablement LED. Disabled zones will have their corresponding FAULT/DISABLED LED illuminated.

Level 2 Access is gained by entering the code 2244 using the numbered buttons. When in panel is in Level 2 the Green LED will flash with a frequency of 1 Hz.

Each successful button press is indicated by the illumination in sequence of the top screen Fault LEDs. If the code is not completed within 20 seconds of the last key press, the system reverts to Level 1.

**NOTE:** If any Fire or Fault events have occurred these must be acknowledged by pressing the Buzzer Silence button to acknowledge each Fault or Fire event before code entry will be accepted.

## **LEVEL 3 – Engineering Functions (4321)**

It is accessed from Level 1 and allows:

- One Man Test
- Silence and reactivate S1 and S2 sounder outputs
- Panel Reset
- Manually activate the sounders (Evacuate function)
- Silence Internal Buzzer
- Program Coincidence
- Program Non-latching Zones
- Program Delayed Zones
- Program Delay Timer

NOTES:

- 1) Changes made at this level affect the factory default settings and the operation of the system. They should only be made by qualified personnel who are fully aware of their effects.
- 2) If any Fire or Fault events have occurred, these must be acknowledged by pressing the Buzzer Silence button to acknowledge each fault and Fire event before code entry will be accepted.
- 3) When in Access Level 3, the occurrence of any Fire or Fault condition the system will automatically exit from Level 3 and revert to Level 2.

To enter Engineering Mode (Access Level 3) enter the code 4321, using the numbered keys (from 1 to 4), which are available on the top right-hand side of the control panel display. Each successful button press is indicated by the illumination in sequence of the Fault LEDs for zones 3, 4, 5 and 6. If the code is not completed within 20 seconds of the last key press, the system reverts to Level 1.

Once this mode is entered the Green LED (SUPPLY) will flash once every 0,5 seconds. To exit this mode at any time, press the RESET button. The panel will revert to Access Level 1. Total removal of power during the programming phase could cause changes not to be saved.

## Panel Status Indicators and Controls

**STATUS**

- ALARM
- FAULT
- DISABLED
- TEST
- SUPPLY
- SYSTEM FAULT

**ZONES**

1 2 3 4 5 6 7 8

ALARM

TEST  
FAULT  
DISABLED

1 2 3 4 5 6 7 8

**CONTROLS**

BUZZER SILENCE 1

RESET 2

LAMP TEST 3

SOUNDERS ACTIVATE/SILENCE 4

**FAULTS**

- SUPPLY FAULT
- BATTERY FAULT
- AUX. SUPPLY FAULT

**IDENTILEAK WATER LEAK ALARM PANEL**

**INSTRUCTIONS**

**GENERAL USER (Access Level 1)**  
To silence internal buzzer press BUZZER SILENCE. To override active delays, during an alarm condition, press DELAYS ACTIVE.

**AUTHORISED USER (Access Level 2)**  
To enter this level enter 4 digit code. Consult Manual for more details.

**EVACUATION**  
Enter Authorised User Code (Access Level 2). Press SOUNDERS ACTIVATE/SILENCE button. Repeat last step to silence sounders.

**ALARM EVENTS**  
Internal Buzzer sounds. System Status Alarm LED is lit. Zones in Alarm will have their respective Alarm LED lit. To silence alarms: First enter authorised user code (Access Level 2). Press SOUNDERS ACTIVATE/SILENCE button.

**FAULT EVENTS**  
Internal Buzzer Sounds. System Status Fault LED is lit. Each fault will be shown by its own LED being lit. Call service engineer.

**DISABLEMENTS**

- OUTPUTS AUXILIARY
- DISABLE SOUNDERS
- SELECTED ZONES
- DELAYS ACTIVE

**VIMPEX** MANUFACTURED IN THE E.U. **CE**

## Status

- **WATER LEAK** – LED used to indicate any LOCKDOWN condition present on panel.
- **FAULT** – LED used to indicate any Fault condition present on panel.
- **DISABLED** – Disabled Status LED used to indicate that the panel has features that have been disabled.
- **TEST** – This LED is active whenever the panel is in TEST MODE, activated in Engineering Mode Access Level 3 only.
- **SUPPLY** - Multi function indicator used to indicate the presence of supply. When in Access Level 1 this LED is permanently lit. If in Access Level 2 (USER CODE 2244) this LED will flash at a rate of once per second. If in Access Level 3 mode (ENGINEERING CODE 4321) this LED will flash faster at a rate of once every 0,5 seconds.
- **SYSTEM FAULT** – This LED will be lit whenever there is a processor failure or corruption of the panel firmware.

## Faults

- **SUPPLY FAULT** – This LED will be ON whenever the Main Supply has been removed or has dropped below 20 Volts.
- **BATTERY FAULT** – Indicates that there is low voltage level on the batteries or the battery charger circuit has failed.
- **AUX. SUPPLY FAULT** – Indicates that the Auxiliary Supply has a fault.
- **SOUNDER FAULT** – If there is a conventional sounder output circuit fault, the general FAULT LED will be lit and the DISABLE SOUNDERS LED in the DISABLEMENTS section will be flashing.
- **RM FAULT** – If there is a RM output circuit fault, the general FAULT LED will be lit and the DISABLE SELECTED ZONES LED in the DISABLEMENTS section will be flashing.

## Zones & Inputs

Individual zone and monitored input indicators are provided for both FIRE/ALARM and FAULT conditions. If any zone is disabled, then its Fault LED will also be used to indicate the disablement of that particular zone/ input. The zone/ input Disabled LED will be ON along with the associated disabled status LED. Flashing Fault LED along with general Fault LED indicates a fault in that zone.

## Control Keys

These four keys can have more than one function. They are numbered to indicate that they are used to enter digits from 1 to 4 for code entry.

- **BUZZER SILENCE (1)** – At Access Level 1 this button is used to silence the panel's internal buzzer. At Access Level 2 and 3 used to confirm/accept changes in programming. Buzzer must be always silenced before entering an access code to other levels.
- **RESET (2)** – Press this button to reset the panel at Access Level 2 or 3.

**NOTE:** If the Sounders S1 and S2 are active, RESET button will not operate until the Sounders are silenced using the SOUNDERS button.

- **LAMPTEST (3)** – Press this button at Access Level 1 or 2 to test all LED indicators and the panel's internal buzzer. Release when test is finished. At Access Level 3, press this button to enter in "one man" test mode.
- **SOUNDERS (4)** – Press once to activate/silence sounders in Level 2. If sounders are active, for example, during a FIRE condition or in the event of an Evacuation action, pressing this button will stop the sounders. Auxiliary Relays are not affected by this action. If a zone is programmed to be delayed, during a FIRE condition, pressing this button while the delay is running will stop the sounders from activating at the end of the delay time. This button is also used, in combination with the DISABLEMENTS buttons at access level 2 or 3, to select the desired configuration (Please refer to DISABLEMENT KEYS and PROGRAMMABLE OPTIONS section in this manual).

**NOTE:** The SOUNDERS button's associated LED is OFF when the Sounders are OFF, ON when the Sounders are ON and FLASHING while a Delay timer is running.

# Disabling

Using these keys requires Access Level 2.

**OUTPUTS AUXILIARY** – Pressing this button will enable / disable the Auxiliary Relays. When the auxiliary Relays are disabled, the OUTPUTS AUXILIARY LED will be ON as well as the general DISABLED LED in the STATUS area.

**DISABLE SOUNDERS** – Pressing this button will enable / disable the conventional sounders circuits. When the conventional Sounders Circuits are disabled, the DISABLE SOUNDERS LED will be ON as well as the general DISABLED LED in the Status area.

**SELECTED ZONES** – Use this button to disable zones Z1 to Z8:

1. Press the SELECTED ZONES button in the disablements area of the control panel. The associated LED will turn ON.
2. Select the desired Zone to enable / disable by pressing the Red Switch (4) consecutively until the Yellow (FAULT) LED that corresponds to the desired zones is ON.
3. Confirm the selection by pressing Green (1) key. Upon confirmation the Red (FIRE) LED will be activated. Remove selection by pressing the Green key again. The corresponding LED will be switched OFF.
4. To exit the function press SELECTED ZONES button.

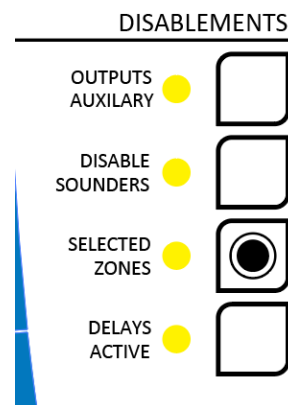

**DELAYS ACTIVE** – Pressing this button will enable the previously programmed delay (at Access Level 3). The corresponding LED will be ON as well as DISABLED LED in the STATUS area when delays are active. In access level 1, during a delay, started by an Alarm condition, pressing this button overrides the delay timer, activating the Fire Relay and the Sounders immediately.

**NOTE:** For information regarding the special functions associated with this buttons when in access level 3 (Engineering Mode), please refer to the PROGRAMMABLE OPTIONS section on this manual.

Disabling LEDs Status Table	
Disabled Circuit	Active Yellow LEDs
Zone 1 to Zone 8	DISABLED + Z1 to Z8
Relays	DISABLED + OUTPUTS AUXILIARY
Sounders	DISABLED + DISABLED SOUNDERS

# Keys Function Table

Buttons			User Level 1		Authorised User Level 2		Engineering User Level 3	
<b>Controls</b>								
<b>Buzzer Silence</b>	1	Green	Insert User Code	Silence Buzzer	Silence Buzzer	Confirm Disablement	Silence Buzzer	Confirm Programmable Selection
<b>Reset</b>	2	-	Insert User Code	-	Reset Panel		Reset Panel	
<b>Lamp Test</b>	3	-	Insert User Code	Lamp Test	Lamp Test		One Man Test	
<b>Sounders Activate/Silence</b>	4	Red	Insert User Code	-	Activate Sounders	Select (Zones disablement)	Activate Sounders	Select
<b>Disablements</b>								
<b>Outputs Auxiliary</b>				-	<b>Enable/Disable Relays</b>		<b>Program/Confirm Coincidence</b>	
<b>Disable Sounders</b>				-	<b>Enable/Disable Sounders</b>		<b>Program/Confirm Non-latching Zones</b>	
<b>Selected Zones</b>				-	<b>Program/Confirm Zones Disablement</b>		<b>Program/Confirm Delayed Zones</b>	
<b>Delays Active</b>				-	<b>Enable/Disable Delays</b>		<b>Program/Confirm Delay Timer</b>	

# Connection Diagrams

## Zones 1 to 8

Two, Four or Eight zones are available for detection device wiring. Each zone has capacity for an 20 probes or 50m of cable per zone. This may be restricted by local regulations.

An active end of line capacitor (10UF/50V bipolar) is supplied for each zone, as part of the monitoring circuit. This must be fitted to the last device of each Zone. If a detection zone is unused, the end of line module must be connected at the panel, if it's not fitted, a fault will be indicated for that zone.

The wiring for each detector zone should be terminated in the relevant terminal blocks at the control panel and the cable screens connected to earth.

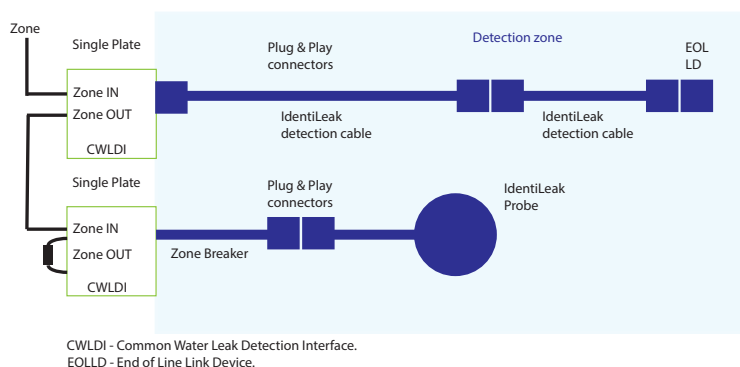

## S1 & S2 Monitored Outputs

These output/sounder circuits have a combined maximum current output of 1 Amps (500mA per circuit). Connected devices (sounders, beacons, bells, pyrotechnic actuators, solenoids, relays, etc.) must be polarised, non-polarised devices trigger a fault on the panel circuit. In order to mitigate this situation a polarization diode should be added when using bipolar devices. With solenoids, relays and bells a flyback diode should also be present.

An end of line resistor (10K Ohm) which is supplied with the panel, must be inserted in the last device for monitoring. If a sounder/output circuit is not used, the EOL resistor should be fitted in the respective control panel output.

The sounder circuits are protected against short circuits, the electronic fuse will reset when the short circuit is removed and the control panel is reset.

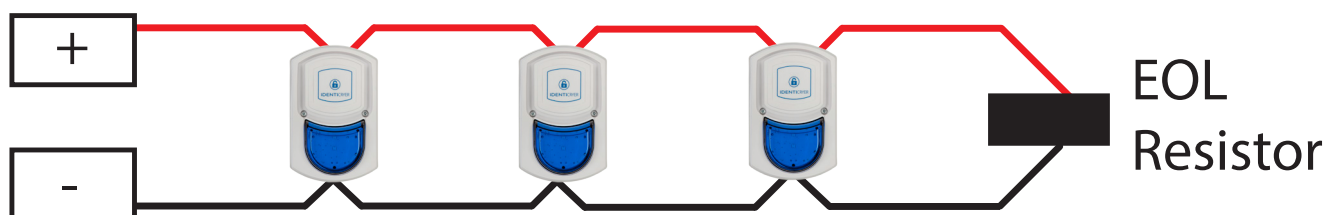

## Auxiliary Inputs - Not Monitored

Identi-Cryer remote activation inputs. All remote inputs are activated using a voltage free dry contact like a relay or manual ON-OFF switch between input and 'C' terminal.

**INPUT DE** – Allows switching between Day and Night operation from a remote location or using a timer clock. When 0V is applied via a voltage free contact, the DELAYS ACTIVE LED will turn ON indicating that the programmed delays are active (Day Operation). When the contact is open, the DELAYS ACTIVE LED will turn OFF and the programmed delays are ignored (Night Operation).

**INPUT EV** – Activates sounders immediately when 0V is applied via a voltage free contact. Sounders will continue to operate until the input is removed.

**INPUT RST** – Panel Reset: The closure of a contact at this input will cause the panel to reset. In order to re-apply a reset to the panel, contact has to be released and reapplied (Pulse action).

**NOTE:** The wiring for each auxiliary input should be terminated in their respective terminals and the cable screens connected to earth.

## Outputs - Monitored

**AUXILIARY SUPPLY OUTPUT** – 28V DC max 300 mA, short circuit protected, supervised. The output is protected against short circuit by an electronic fuse which resets when the fault is cleared and the panel is reset.

**RM** – Activate when a disablement zone is selected.

## Outputs - Non Monitored

**ALARM Relay** – Provide Alarm signal to external devices. Changeover contact rating: 30V DC / 2 A. Active until Reset.

**FLT Relay** – Provide normally closed Fault signal to external devices. Relay contact rating: 30V DC / 2 A. max resistive. Also Active for microprocessor fault. Active until reset and all faults are cleared. Relay contact will open when any fault is present on the system.

**NOTE:** The wiring for each output should be terminated in their respective terminals and the cable screens connected to earth.

# Commissioning

The Identi-Leak Control Panel is supplied ready to operate as a standard conventional Alarm control panel. Additional function programming is described in the next section.

The default settings for the panel are as follows:

- All zones Latching
- All Timers OFF
- No Zone Coincidence
- Authorized User Access Code (Level 2): 2244
- Alternatively, access to Level 2 can be entered using the Physical Access Key provided
- Engineering Access Code (Level 3): 4321.

## Preparation

- Check zone cables and ensure all field connections are made, ensure that all EOL devices are fitted to the last call point or sounder of each circuit. EOL Capacitors should be fitted to zones or remote monitored inputs. EOL Resistors should be applied to sounder/output circuits.
- Connect zone and sounder lines or terminate with EOL.
- Remove the mains fuse.
- Connect mains supply according to local mains voltage. Ensure good earth connection.
- Fit batteries (Do not connect).
- Insert mains fuse and connect batteries - Observe correct polarity.

## Commissioning

- If all is normal only the Green “supply” LED should be illuminated.
- If any Faults are indicated, they should be corrected before proceeding.
- Initiate lamp test and check LEDs and internal buzzer operation.
- Test each key for correct functioning.
- Test all detectors, manual call points, sounders, relays etc. for proper operation.

## Testing Zones - Z1 to Z8

- Set zones to Test mode with level 3 access.
- Press LAMP TEST key.
- Activate device according to manufacturer specification.
- Wait until the response indicator on the device indicates Red.
- Reset initiating devices or until detectors are normal.
- Automatic reset after (10 sec)

**NOTE:** After testing is completed, be sure to return the control panel to normal operating mode.

## Testing S1 and S2 Output Circuits

- Initiate sounder test by entering Access Level 2 and pressing SOUNDERS ACTIVATE/SILENCE.
- Press again to Stop

## TESTING – ALARM and FLT Relays

- With the system in normal operating mode induce an Alarm and a Fault to confirm proper operation of relays and external devices at the end of any programmed delay
-

# Programmable Options

The Identi-Cryer control panel has a number of programmable options to help the engineer customize the system to meet the customer's requirements. To access these options it is necessary to enter Access Level 3.

## ONE MAN TEST

After entering Engineering Mode (Access Level 3) press the LAMP TEST button. Release button and the TEST LED will be on along with the fault LED for all zones that are available for testing indicating that the panel is in TEST mode.

Zones that are in Fault or are Disabled will not have their LED illuminated.

Test the zones accordingly with installation requirements. At each zone activation, the corresponding zone FIRE LED will light up for 5 seconds.

Zones will automatically reset after 10 seconds. Internal Buzzer and SOUNDERS will operate for 1 second. To end TEST mode press the LAMP TEST button.

To exit Engineering Mode (Access Level 3), press the RESET button.

## COINCIDENCE

- After accessing Level 3, press the OUTPUTS AUXILIARY button in the disablements area of the control panel. The associated LED will turn ON.
- Select the pair of zones desired to work in Coincidence by pressing the Red Switch (4) consecutively until the Yellow (FAULT) LED that corresponds to the desired zones pair is ON (Please refer to the table below for additional details).
- Confirm the selection by pressing GREEN (1) key. Upon confirmation the Red (FIRE) LED will be activated. Remove selection by pressing the GREEN key again. The corresponding LED will be switched OFF.
- To exit the function press OUTPUTS AUXILIARY button.

## NOTES:

- Coincidence only has an effect on the ALARM Relay.
- If one of the programmed Paired Zones is disabled, the Fire Relay will not activate in the event of a Fire in the other Zone of the pair.
- Non-latching Zones should not be set to Coincidence.

Coincidence Configuration Table									
Active RED LEDs During Set up	All LEDs off	Z1	Z2	Z3	Z4	Z5	Z6	Z7	Z8
Pair of Zones with Coincidence	No Coincidence Programmed	Z1+ Z2	Z3+ Z4	Z5+ Z6	Z7+ Z8	-	-	-	-

## Non-Latching Zones

- After accessing Level 3, press the DISABLE SOUNDERS button in the disablements area of the control panel. The associated LED will turn ON.
- Select the desired Zone to work as non-latching by pressing the Red Switch (4) consecutively until the Yellow (FAULT) LED that corresponds to the desired zones is ON.
- Confirm the selection by pressing GREEN (1) key. Upon confirmation the Red (FIRE) LED will be activated. Remove selection by pressing the GREEN key again. The corresponding LED will be switched OFF.
- To exit the function press DISABLE SOUNDERS button

## Delayed Zones

- After accessing Level 3, press the SELECTED ZONES button in the disablements area of the control panel. The associated LED will turn ON.
- Select the desired zone to have a delayed operation by pressing the Red Switch (4) consecutively until the Yellow (FAULT) LED that corresponds to the desired zone is ON.
- Confirm the selection by pressing GREEN (1) key. Upon confirmation the Red (FIRE) LED will be activated. Remove selection by pressing the GREEN key again. The corresponding LED will be switched OFF.
- To exit the function press SELECTED ZONES button.

## Delay Timer

- After accessing Level 3, press the DELAYS ACTIVE button in the disablements area of the control panel. The associated LED will turn ON.
- Select the desired Delay Time by pressing the Red Switch (4) consecutively until the Yellow (FAULT) LED that corresponds to the desired zone is ON (Please refer to the table below for additional details).
- Confirm the selection by pressing GREEN (1) key. Upon confirmation the Red (FIRE) LED will be activated. Remove selection by pressing the GREEN key again. The corresponding LED will be switched OFF.
- To exit the function press DELAYS ACTIVE button.

Delay Configuration Table									
Active RED LEDs During Set up	All LEDs off	Z1	Z2	Z3	Z4	Z5	Z6	Z7	Z8
Corresponding delay in Minutes	0	1	2	3	4	5	6	7	8

## NOTES:

- In order to the DELAYED ZONES and DELAY TIMER configuration be active, the delays have to be activated at Access Level 2 (refer to DISABLEMENTS Keys section of this manual).
- The programmed delays will have no effect on the FIRE Relay Output. The delays will affect S1 and S2 Outputs only.
- In a case of a FIRE event, pressing the DELAYS ACTIVE button at access level 1 or 2 will override any delay taking place.

# Troubleshooting - Fault Indicators

**NOTE:** Troubleshooting of any fault on the panel should only be carried out by qualified technicians.

**General Fault** - The General fault LED is illuminated whenever there is a fault on the system. It is always lit along with at least one other fault indicator which gives more detail relating to the fault. The General Fault LED is flashing at a rate of once per second indicates that the communication between the ORION panel and one or more of the modules / repeaters has been lost or is corrupted.

**Zone Fault** - This type of fault will indicate that there is either a short or open circuit condition on the zone circuit. Revise wiring.

**Sounder Fault** - This type of fault indicates that there is either a short or open circuit condition on one of the conventional sounder circuits. Revise wiring.

**Supply Fault** - Associated with a low voltage (below 20 V) present at the input of the power supply or the removal of the main power supply. Measure voltage levels and verify electrical mains fuse.

**Battery Fault** - This fault is present when there is a low voltage below 20V DC at the battery terminals or if there is a battery charger problem. Charger problems can be caused by panel's hardware failure or batteries that have not been connected in the specified manner as indicated in this manual, on the installation section. Verify if batteries are properly connected. Measure the voltage at the battery terminals. If it is below 21V DC replace batteries. Remember to verify also the main electrical fuse.

**NOTE:** Don't short circuit battery terminals in order to verify battery charge. Only use batteries which are batteries which are 12V DC.

**System Fault** - This FAULT indicates that there is a fault at the main processor level. In this particular fault, the panel's main board needs to be replaced or repaired.

## Standby Battery Calculation

Battery capacity should be between 2 x 2.4 Ah 12V DC and 2 x 7 Ah 12V DC.

The battery Ah required for a given installation is calculated from the following formula:

$$\left( \begin{array}{l} \text{Quiescent current in} \\ \text{mA of the panel with} \\ \text{everything connected} \end{array} \times \begin{array}{l} \text{Standby time} \\ \text{required in} \\ \text{hours divided} \\ \text{by 1000} \end{array} \right) + \left( \begin{array}{l} \text{Alarm Current in} \\ \text{Amps} \\ \text{(Sounder Load)} \end{array} \times \begin{array}{l} \text{Alarm Time} \\ \text{in Hours} \end{array} \right) + 20\%$$

Round the result to the next available battery size. Quiescent current of the panel with everything is found by adding the standby current of all connected devices to the standby current of the panel (38 mA). Consult the manual for the individual devices to confirm the standby current.

3500148\_REV0100

We reserve the right to change or amend any design or specification in line with our policy of continuing development and improvement.

Vimpex Ltd, Star Lane, Great Wakering, Essex, SS3 0PJ, UK  
Vimpex Europe BV / Vimpex Sweden AB

+44 (0) 1702 216 999 / sales@vimpex.co.uk / vimpex.co.uk

Registered in England No.2915112 Registered Address: Star Lane, Great Wakering, Essex, SS30PJ, United Kingdom



Fire Industry Association



# Commissioning Certificate