

ZP755HAV-2 Addressable Horn Sounder/Visual Indicator Installation Sheet

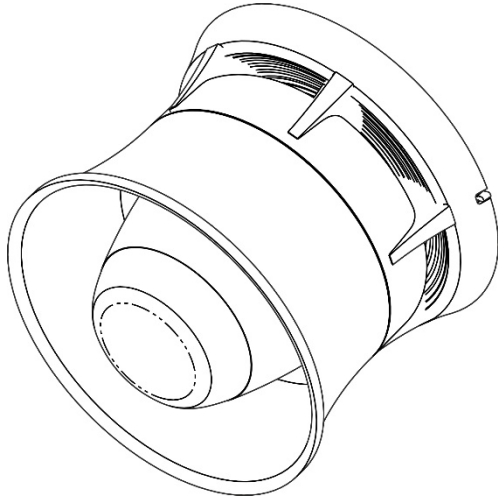

Installation

To install the device:

1. Wire the base
2. Set the power source (loop or external)
3. Set the address
4. Set the device and operating modes
5. Set the tone
6. Set the volume
7. Mount the sounder onto the base

The details of each step are given below.

Wiring the base

Wire the base (not supplied) as shown in Figure 1.

Figure 1: Wiring the base

Description

Caution: This product does not comply with EN 54-23 and must not be used in fire alarm installations where fire notification beacons are required.

The ZP755HAV-2 is an addressable horn sounder/visual indicator designed for use in Ziton addressable fire detection and alarm systems.

The unit includes a potentiometer for a volume control, DIP switches for setting the address, operating mode, and tone, and two jumpers to set the power source (loop or external 24 VDC supply).

Table 1: Models

Model	Description
ZP755HAV-2R	Horn sounder, red
ZP755HAV-2P	Horn sounder, polar white
SPB-2R	Base, red
SPB-2P	Base, polar white

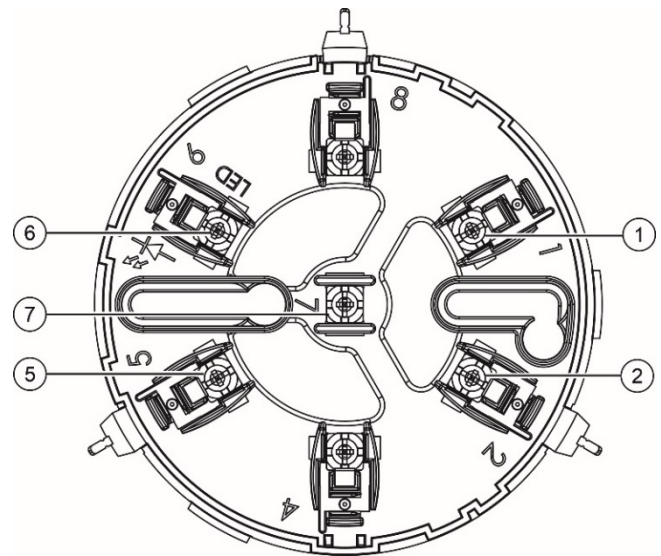

- | | |
|------------------------------|------------------|
| 1. Ext. 24 VDC+ IN/OUT | 6. Loop - IN/OUT |
| 2. Ext. 24 VDC ground IN/OUT | 7. Shield |
| 5. Loop+ IN/OUT | |

Setting the power source

Use jumpers J1 and J2 to set the power source, as shown in Figure 2.

Figure 2: Setting the power source

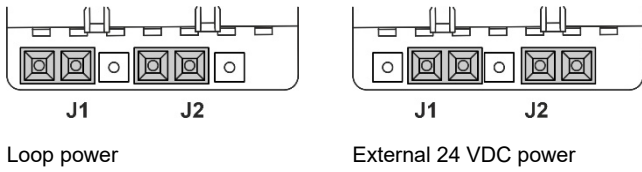

Caution: The external power supply must be EN 54-4 compliant and of sufficient capacity for the installation requirements.

Setting the address

Use DIP switch SW1 (see Figure 3) to set the device address from 1 to 127.

Each switch has a decimal value, as shown below. The device address is the sum of the switch values.

For example, to set device address 007, set switches 1, 2, and 3 to ON and all other switches to OFF.

Note: The switch *values* determine the address, not the switch numbers.

Switch	1	2	3	4	5	6	7
Value	1	2	4	8	16	32	64

Figure 3: Setting the address

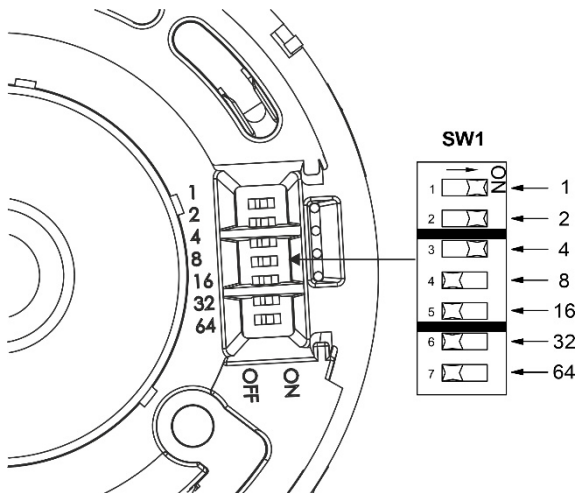

Mode, tone, and volume configuration

Use DIP switch SW2 (see Figure 4) to set the operating mode, device mode, and tone. Use the potentiometer to set the volume.

Figure 4: Mode, tone, and volume configuration

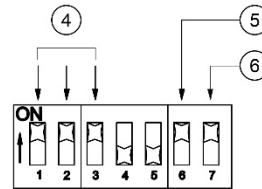
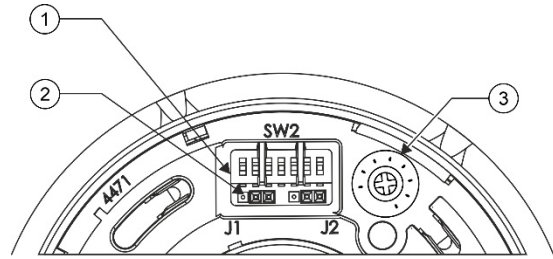

1. DIP switch SW2
2. Power selection jumpers
3. Volume control potentiometer
4. Tone configuration
5. Device mode configuration
6. Operating mode configuration

Setting the operating mode

The device only operates as a dedicated stand-alone sounder and DIP Switch SW2-7 must be on.

Table 1: Setting the operating mode (SW2-7)

SW2-7 Setting	Mode
On	The sounder operates as a dedicated stand-alone sounder with a unique loop address
Off	Not used – SW2-7 must be on

Setting the device mode

Use DIP Switch SW2-6 to configure the device mode, ZP755 or ZP754 Emulation.

Table 2: Setting the device mode (SW2-6)

SW2-6 Setting	Mode	Output signal
On	ZP754 Emulation [1]	Two fixed tones
Off	ZP755	User-selectable two-tone operation and full monitoring

[1] ZP5 panels or ZP3 panels with legacy firmware only.









Setting the tone

In device mode ZP755, use DIP Switches SW2-1, SW2-2, and SW2-3 to configure the tone. Two tones are available, as shown in Table 3.

Note: In the ZP3 panel I/O mapping menu, outputs are programmed as "steady" or "flashing" as follows:

- Tone A (primary/alert tone), ZP3 setting "fast flash/slow flash"
- Tone B (secondary/evacuation tone), ZP3 setting "steady"

Table 3: Setting the tone

Device mode	SW2-1, 2, 3	Tone A	Tone B
ZP755		Intermittent	Continuous
ZP755		Continuous	Intermittent
ZP755		Continuous	Two-tone
ZP755		Two-tone	Continuous
ZP755		Two-tone	Intermittent
ZP755		Intermittent	Two-tone
ZP755		Not used	
ZP754 [1]		Intermittent	Continuous

[1] DIP switch SW2-6 on – see "Setting the device mode" on page 2.

Setting the volume

Use the volume control potentiometer (see Figure 4) to set the volume.

WARNING: To conform to EN 54 Part 3 sound output levels, the volume control *must* be set to the full clockwise position. If the volume is adjusted for any reason, it *must* be returned to the full clockwise position.

Mounting the sounder

Align the sounder to the plug-in base. Push up (A), and then turn the sounder until it clicks into place (B). Push the sounder up once more to engage (C). See Figure 5.

Reverse the above procedure to remove the sounder from the base.

Figure 5: Mounting the sounder

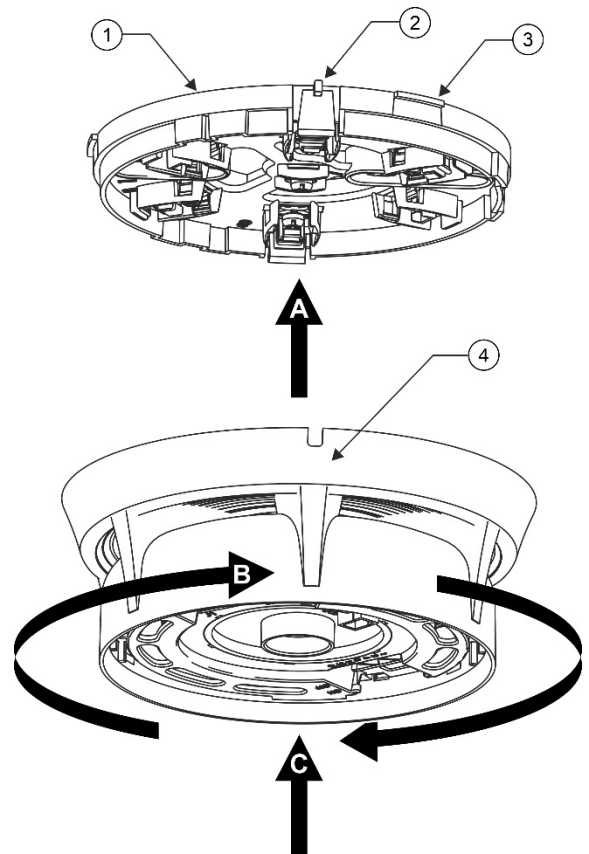

1. Plug-in base
2. Release/lock catch
3. Release aid (3X)
4. Addressable sounder

Maximum number of devices per loop

For loop-powered devices, use Table 4, and Figure 6, to determine the quantity of detectors and sounders that can be connected to the loop.

Figure 6: Maximum number of devices per loop

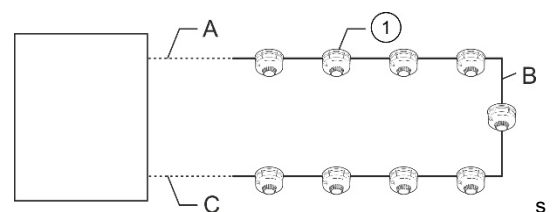

- A. Cable length panel to first sounder
- B. Cable length first to last sounder
- C. Cable length last sounder to panel
1. Detectors and Sounders

Table 4: Maximum number of devices per loop

A	B	C	Quantity allowed [1]
10 m	980 m	10 m	80 detectors and 20 sounders 100 detectors and 15 sounders
100 m	800 m	100 m	80 detectors and 20 sounders 100 detectors and 15 sounders
200 m	600 m	200 m	60 detectors and 20 sounders 100 detectors and 15 sounders
300 m	400 m	300 m	40 detectors and 20 sounders 110 detectors and 15 sounders

[1] Using a two-core shielded loop of 1000 m, cable size 1.5 mm²

Specifications

Operating voltage	
External supply	18 to 30 VDC
Loop power	16 to 20.5 V pulsed
Current (loop powered)	
Quiescent (RMS)	1.3 mA
Alarm (RMS)	8.5 mA
Alarm (peak)	14 mA max.
Current (externally powered)	
Loop quiescent (RMS)	800 µA
Loop alarm (RMS)	1 mA
Loop alarm (peak)	4.9 mA
External quiescent (RMS)	570 µA
External alarm (RMS)	7.2 mA
Sound frequency	
Continuous tone [1]	980 Hz
Intermittent tone	980 Hz (0.5 s on/off)
Two-tone warble [1]	980 Hz/670 Hz
Sound distribution	Wide
Strobe frequency	Flash rate 1.3 seconds
Anechoic sound levels	See Figure 7
Monitoring	
Loop	Open and short circuit fault
Sound output level	Self test facility
Addressing method	DIP switch
Mounting	Surface, with plug-in base
Wiring	Two-core loop, shielded twisted pair
Material	Moulded thermoplastic
Colour	Red or polar white
Environmental	
Operating temperature	-10 to +60°C
Storage temperature	-20 to +70°C
Relative humidity	10 to 95% noncondensing
Weight	305 g
Dimensions (Ø × D)	127 × 113 mm

[1] Certified to EN 54-3

Figure 7: Anechoic sound levels

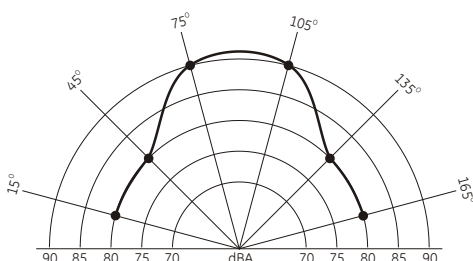

Regulatory information

This section provides a summary on the declared performance according to the Construction Products Regulation (EU) 305/2011 and Delegated Regulations (EU) 157/2014 and (EU) 574/2014.

For detailed information, see the product Declaration of Performance (available at firesecurityproducts.com).

Conformity	CE
Notified/Approved body	0370
Manufacturer	KGS Safety System (Hebei) Co. Ltd., 80 Changjiang East Road, QETDZ, Qinhuangdao 066004, Hebei, China. Authorized EU manufacturing representative: KGS Fire & Security B.V., Kelvinstraat 7, 6003 DH Weert, Netherlands.
Year of first CE marking	14
Declaration of Performance number	360-5201-0499
Product Identification	ZP755HAV-2R, ZP755HAV-2P
Intended Use	See the product Declaration of Performance
Declared performance	See the product Declaration of Performance
	2012/19/EU (WEEE Directive): Products marked with this symbol cannot be disposed of as unsorted municipal waste in the European Union. For proper recycling, return this product to your local supplier upon the purchase of equivalent new equipment, or dispose of it at designated collection points. For more information see: recyclethis.info .

Contact information and product documentation

For contact information or to download the latest product documentation, visit firesecurityproducts.com.

Product warnings and disclaimers

These products are intended for sale to and installation by qualified professionals. KGS Fire & Security cannot provide any assurance that any person or entity buying its products, including any “authorized dealer” or “authorized reseller”, is properly trained or experienced to correctly install fire and security related products.

For more information on warranty disclaimers and product safety information, please check <https://firesecurityproducts.com/policy/product-warning/> or scan the QR code:

